

USER AND INSTALLATION MANUAL

Ecosine Max Passive Harmonic Filters

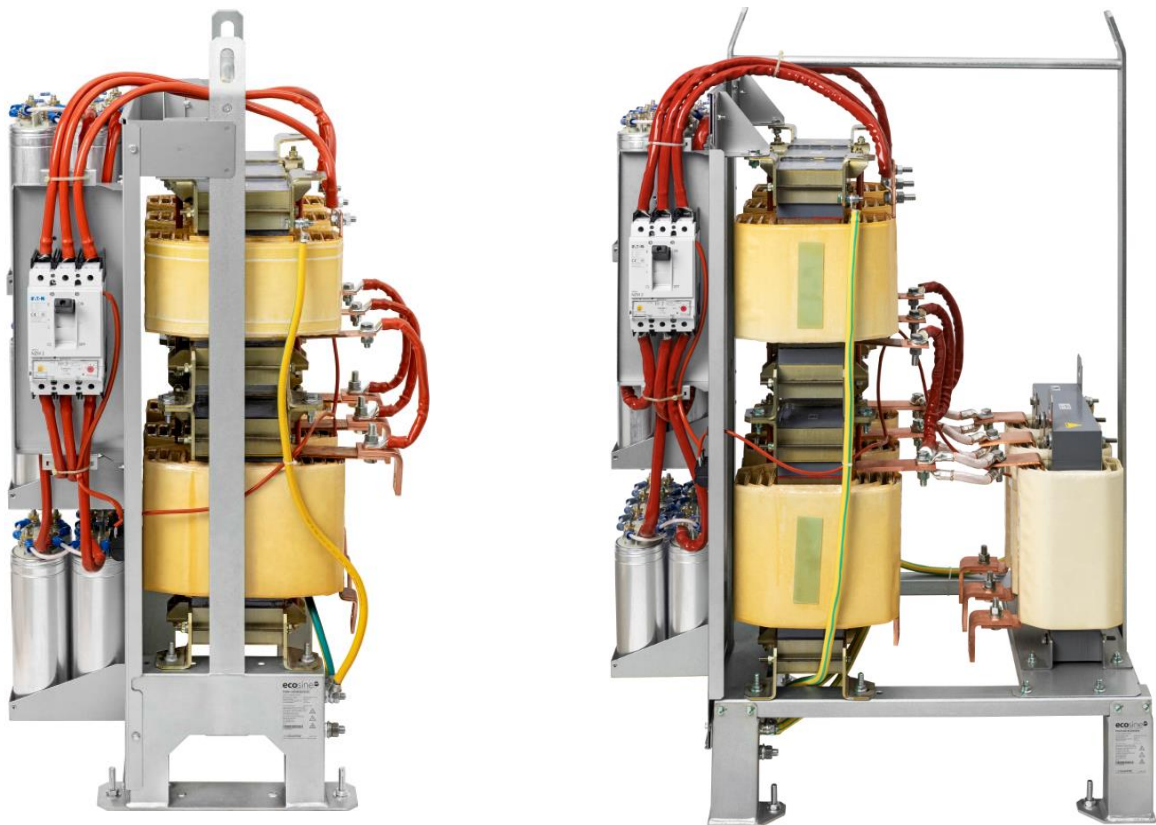

Revision: 03 (July 2023)

English version (original instructions)

The most current edition of this document (PDF format) and official translations can be obtained from your contact of the Schaffner organization or at schaffner.com on the product page.

Other technical documentation of our products is also available in the download area of our website schaffner.com.

Document name:

User and Installation Manual Ecosine Max Passive Harmonic Filters rev03.pdf

Valid for Ecosine Max Passive Harmonic Filters version:

FN3470/FN3471 (50 Hz) for 380–415 VAC

FN3480/FN3481 (50 Hz) for 440–480 VAC

FN3472/FN3473 (60 Hz) for 380–415 VAC

FN3482/FN3483 (60 Hz) for 440–480 VAC

Version history

Revision	Date	Description
01	February 2020	Initial version
02	October 2020	<p>Tables formatting in the whole document (table pasted as picture from datasheet were converted to real editable table to allow a better translation of the document and possible future updates)</p> <p>Typo corrections. Better harmonization of technical terms within the document and between products line</p> <p>Sections 3.1 to 3.4 specification of insulation class SCH-155(F) removed (mistake from document), all versions use insulation class SCH-200(N)</p> <p>Section 3.6.1 Table 20 addition of cross section in AWG/kcmil and updated according to UL requirement.</p> <p>Section 3.6.2 added for trap disconnect jumper terminals cables requirement.</p> <p>Section 3.6.3 added - auxiliary cables requirement.</p> <p>Section 3.8 added – thermal switch specifications.</p> <p>Section 3.9 Table 24 addition of part for reference cabinets (line 6 to 8)</p> <p>Section 3.10 new requirement for cooling, including air flow, air inlet and additional pictures for proper opening requirement at the bottom and back of the cabinet.</p>
03	July 2023	<p>Document template updated to reflect the new Schaffner branding.</p> <p>Minor corrections and clarification across the document</p> <p>Section 3.5.2 current derating by altitude, new calculation.</p> <p>Addition of Figure 12 and Figure 13 drawings of J versions.</p> <p>Section 5.3 addition of pictures for J versions.</p> <p>Section 8.3.5 added for more clarification about the switch circuit breaker selection and installation for J versions Ecosine Max.</p> <p>WARNING: Section 8.3.6 important correction regarding the sizing of the capacitor contactor used with the J versions of Ecosine Max.</p>

i. Ecosine Max Passive Harmonic Filters

Ecosine Max product highlights

Schaffner Ecosine Max Passive Harmonic Filters are configurable products which provide a tailored solution to each specific problem of current harmonics mitigation of 3-phase non-linear loads.

The eight product lines, FN3470/FN3471, FN3480/FN3481, FN3472/FN3473 and FN3482/FN3483 are applicable for low voltage 50 Hz and 60 Hz systems and they are particularly suitable for AC and DC motor drives, battery chargers and other power electronics applications with 6-pulse front-end rectifiers.

Ecosine Max Passive Harmonic Filters technology represents an evolution of the previous generations of passive harmonic filters and introduces following aspects of novelty:

Ecosine Max is designed for the most demanding harmonic mitigation tasks. Ecosine Max filters FN3470/71, FN3472/73, FN3480/81 and FN3482/83 can be applied to drives with or without DC-link choke present, different THDi @ rated power can be achieved, as shown in the following table. The new generation Ecosine Max filters guarantee compliance with the toughest requirement of IEEE-519 and other stringent international power quality standards.

Table 1 Ecosine Max product variants and performance

	FN3470	FN3471	FN3480	FN3481	FN3472	FN3473	FN3482	FN3483
Grid frequency	50Hz				60Hz			
Nominal operating voltage	3x380-415VAC		3x440-480VAC		3x380-415VAC		3x440-480VAC	
For 6-pulse diode rectifier without DC-link choke	<5% THDi	<8% THDi	<5% THDi	<8% THDi	<5% THDi	<8% THDi	<5% THDi	<8% THDi
For 6-pulse diode rectifier With 4% DC-link choke	3.5% THDi	<5% THDi	3.5% THDi	<5% THDi	3.5% THDi	<5% THDi	3.5% THDi	<5% THDi

- **Ecosine Max demonstrates superior partial load performance.** The excellent performance of Ecosine Max filters not only reflect on mitigating harmonic current and bringing the THDi down to 5% (diode rectifiers @ rated power), but also introducing minimum reactive power, even at partial or no-load condition. The displacement power factor remains at $\cos\phi > 0.98$ @ 50% load.
- **Most compact open frame design for cabinet integration.** The upgraded version of the Schaffner power quality simulator SchaffnerPQS3 (pqs.schaffner.com) provides the possibility to simulate Ecosine Max Passive Harmonic Filters within an electrical system. It furthermore offers quick and accurate performance checks.

This user manual is intended to support designers, installers, and application engineers with filter selection, installation, application, and maintenance. It provides helpful solutions to overcome harmonics mitigation challenges and answers frequently asked questions.

If you require additional support, please feel free to contact Schaffner or our local partner.

ii. Performance Guarantee

By selecting and installing the appropriate Ecosine Max Passive Harmonic Filters in a variable frequency AC drive application (variable speed drive application) within our published technical specifications, we guarantee that the input current distortion will be less than or equal to 5% THDi for standard Ecosine Max series filters at rated power. Ecosine Max filters can also provide similar performance in other drive applications such as constant torque, DC drives or other phase controlled rectifiers, e.g. SCR drives, but actual THDi levels can vary by load and/or speed and/or firing angle of thyristors and therefore cannot be guaranteed. Consult Schaffner or our local representative for assistance when applying ecosine filters on these types of equipment.

iii. Minimum system Requirements

The guaranteed performance levels of this filter will be achieved when the following system conditions are met:

- Type of load: Any 3-phase equipment with front-end six-pulse diode rectifier, with or without DC-link choke
- Type of source: 3-phase power line without neutral
- Line impedance: <3% (calculated for the rated filter power)
- Line frequency: 50 Hz \pm 1 Hz (FN3470/71, FN3480/81), 60 Hz \pm 1 Hz (FN3472/73, FN3482/83)
- Line voltage: Nominal line voltage \pm 10%
- Line voltage unbalance: <1%
- Line voltage distortion: THDv <2%

If a properly sized and installed filter fails to meet the 5% THDi level, Schaffner will provide the necessary application engineering support or filter replacement at no charge.

iv. Important user notice



Schaffner Ecosine Max Passive Harmonic Filters are designed for the operation on the input (grid) side of power electronic equipment with six-pulse rectifier front-end in balanced three-phase power systems, like typically used in AC or DC motor drives and high power DC supplies. Filter suitability for a given application must be determined by the user on a case-by-case basis. Schaffner will not assume liability for any consequential downtimes or damages resulting from use or application of ecosine filters outside of their specifications. Ecosine filters are not designed for single-phase or split-phase applications.

i. General Safety Notes and Installation Guidelines (Cautions and Warnings)

Important Information

These general safety notes refer to the group of power quality filters including active and passive harmonic filter (AHF, PHF), AC line chokes and output filters. Do not attempt to install, operate, maintain or inspect power quality filters until you have read through the safety notes and installation guidelines as well as installation manual and product specification. Do not use any Schaffner product until you have a full knowledge of the equipment, safety notes and installation guidelines. The same applies to all warnings placed on the filters. Please ensure that those are not removed and their legibility is not influenced by external factors.

The following symbols, terms and designations are used in these general safety notes and installation guidelines:

Label	Description
 CAUTION	Follow these instructions to avoid hazardous conditions which could cause minor or moderate injury or may cause damages to the unit.
 WARNING	Follow these instructions to avoid hazardous conditions which could result in death or serious injury.
NOTICE	Indicates content to be noted by the reader.

General Installation Notes

- Please read and follow the safety and application notes below.
- Carefully inspect the shipping container and the product prior to the installation. In case of visual damage, don't install the filter and file a claim with the freight carrier involved.
- Filters may be heavy. Follow the instructions for lifting heavy equipment defined by your company.
- Use an appropriately sized threaded bolt for every mounting hole/slot provided by the filter flange. The strength class of the bolt must be determined by the installer, depending upon filter weight and the material of the mounting surface.
- Connect the filter to the protective earth (PE) terminal(s).
- Remove all line side power, then connect the phase terminal(s) and neutral terminal (if any) of the filter. The filter label may also indicate LINE (grid side terminals) and LOAD (power electronics terminals).
- For the electrical connection of the filter terminals, apply the torques recommended on the filter label and/or in the published filter datasheets.
- Cable or busbar cross sections have to be chosen in accordance with national and international electric codes and applicable product standards governing the equipment that will incorporate the power quality filters and the equipment in use.
- Some filters provide additional terminals, e.g. for over-temperature monitoring. These features have to be properly used before energizing the filter. If uncertain, please consult your local Schaffner representative.
- Active Harmonic Filters (AHF) are working with current transformers (CTs which are a 3rd party product and which are typically installed in electrical equipment with lethal high voltage levels. Before attempting to install CTs read the CT installation safety page provided by the CT manufacturer. Always consider transformer as a part of the circuit to which it is connected, and do not touch the leads and terminals or other parts of the transformer unless they are known to be grounded.
- In order to get the maximum benefit out of your power quality filter, please also consult additional user manuals, installation manuals, whitepaper and other material, published in the download section of www.schaffner.com. These additional guidelines provide helpful hints for equipment related topics as well as technical knowledge.

Safety Notes and Regulations



















1. Label on equipment 2. Safety note category	Safety note regulations
  WARNING	Equipment installation, start-up, operation and maintenance (if any) have to be carried out by a trained and certified electrician or technician, who is familiar with safety procedures in electrical systems. Non-qualified persons are not allowed to use, install, operate or maintain PQ filters!
  WARNING	High voltage potentials are involved in the operation of power quality equipment. Always remove power before handling energized parts of the filter, and let ample time elapse for the capacitors to discharge to safe levels (<42V). Residual voltages are to be measured both line to line and line to earth.
  CAUTION	Correct protective earthing of the equipment must be established and the user must be protected against supply voltage in accordance with applicable national and local regulations. Always practice the safety procedures defined by your company and by applicable national electric codes when handling, installing, operating or maintaining electrical equipment.
  CAUTION	Some product may include EMC filters which may cause leakage currents to ground. Always connect the filter to protective earth (PE) first, then continue with the wiring of phase/neutral terminals. When decommissioning the filter, remove the PE connection at the end.
  WARNING	Using the direct OFF setting in AHF does not disconnect the equipment from mains and is thus not to be used as a safety switch.
  CAUTION	Follow the general installation and environmental condition notes closely. Ensure that cooling slots (if any) are free from obstructions that could inhibit efficient air circulation. Operate the filter within its electrical, mechanical, thermal and ambient specifications at all times.
  CAUTION	Power quality filters are lossy electrical components. Parts/surfaces of the equipment may get hot under load operating conditions.
 NOTICE	At altitudes above 2000m, please contact Schaffner prior to installation.
 NOTICE	Filter suitability for a given application must ultimately be determined by the user (the party that is putting the filter into operation) on a case by case basis. Schaffner will not assume liability for any consequential downtimes or damages resulting from use of filters outside their specifications.
  CAUTION	In case of uncertainty and questions please contact your local Schaffner partner for assistance (details per region available at www.schaffner.com).

Table of Contents

1 Ecosine Max Passive Harmonic Filters designation	8
1.1 Distinguishing between series	8
1.2 Explanation of Ecosine Max designation	9
2 Filter selection.....	11
2.1 Filter selection tables FN3470/FN3471 (50 Hz, 3×380 ... 415 VAC).....	13
2.2 Filter selection table FN3480/FN3481 (50 Hz, 3×440 ... 480 VAC).....	15
2.3 Filter selection table FN3472/FN3473 (60 Hz, 3×380 ... 415 VAC).....	17
2.4 Filter selection table FN3482/FN3483 (60 Hz, 3×440 ... 480 VAC).....	19
3 Filter description	21
3.1 General electrical specifications FN3470/FN3471 (50 Hz filters)	21
3.2 General electrical specifications FN3480/FN3481 (50 Hz filters)	22
3.3 General electrical specifications FN3472/FN3473 (60 Hz filters)	23
3.4 General electrical specifications FN3482/FN3483 (60 Hz filters)	24
3.5 Additional electrical specifications.....	25
3.5.1 Clearance derating by altitude.....	25
3.5.2 Current derating by altitude	25
3.6 Cable cross-section requirement.....	25
3.6.1 Power terminals.....	25
3.6.2 Trap disconnect jumper terminals	28
3.6.3 Auxiliary terminals	28
3.7 Earth terminals screw and torque.....	28
3.8 Thermal protection switch specifications	29
3.9 Cabinet specifications.....	29
3.10 Cooling requirement.....	31
3.10.1 Additional requirement for cooling.....	33
3.11 Mechanical frame sizes.....	35
3.12 Ecosine Max Passive Harmonic Filters footprint.....	36
3.13 Filter performance	38

3.14	Functional diagram.....	40
3.14.1	Filter configuration	40
3.14.2	Filter configuration -E0XXJXX.....	41
4	Ecosine Max filters schematics and working principle.....	42
5	Filter appearance and elements.....	43
5.1	Mechanical design of FN3470/80/72/82 (with load choke present).....	43
5.2	Mechanical design of FN3471/81/73/83 (without load choke present)	45
5.3	Mechanical design of filters with trap disconnect jumper terminal option	46
6	Performance estimation using SchaffnerPQS	48
7	Filter application	49
8	Filter installation	50
8.1	Step 1: Visual inspection	50
8.2	Step 2: Mounting.....	51
8.2.1	Fixation	52
8.2.2	Screws and bolts selection	53
8.2.3	Filter placement	53
8.3	Step 3: Wiring.....	55
8.3.1	Verify safe disconnection of all line side power.....	55
8.3.2	Carefully connect protective earth (PE) cable to adequate earth potential close to ecosine filter	55
8.3.3	Connect PE cable of Ecosine filter	55
8.3.4	Connect Ecosine main terminals to the respective phase on the line and load/rectifier	56
8.3.5	Install an external switch circuit breaker (J versions only)	57
8.3.6	Install external capacitive current control	57
8.3.7	Connect monitor switch TS- TS'	58
8.3.8	Connect auxiliary switch AS- AS'	58
8.3.9	Install and connect the switch remote operator.....	59
8.3.10	Fuses.....	60
9	Filter maintenance	62
9.1	Maintenance schedule	62

9.2	Power capacitors	63
9.2.1	Storage of capacitors	63
9.3	Electrical connections.....	63
10	Trap circuit disconnect	64
11	Troubleshooting	65
12	Abbreviation	65

1 Ecosine Max Passive Harmonic Filters designation

1.1 Distinguishing between series

The main difference between FN3470 (FN3472, FN3480 FN3482) and FN3471 (FN3473, FN3481, FN3483) is the filter configuration, which is clearly shown in Figure 1 and Figure 2 below. FN3470, FN3472, FN3480 and FN3482 filters contain 3 chokes, which enables them to handle the toughest harmonic mitigation task and to achieve very high performance (5% THDi). FN3471, FN3473, FN3481 and FN3483 contain 2 chokes, they are optimal choice if the THDi requirement is lower or for drives with DC-link choke present. The performance of all product variants at different drive setup can be found in Table 1.

E0XXSXX

- For rectifiers without DC-link choke
- Filters contain trap disconnect switch

E0XXJXX

- For rectifiers without DC-link choke
- Filters contain trap disconnect jumper

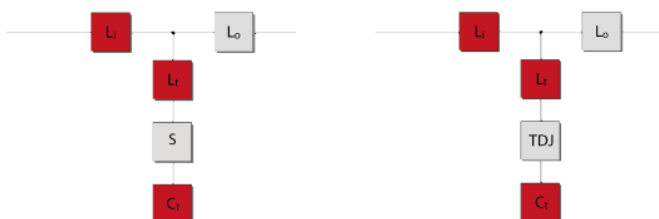

Figure 1 Filter configuration of FN3470, FN3472, FN3480 and FN3482

E0XXSXX

- For rectifiers with and without DC-link choke
- Filters contain trap disconnect switch

E0XXJXX

- For rectifiers with and without DC-link choke
- Filters contain trap disconnect jumper



Figure 2 Filter configurations for FN3471, FN3473, FN3481 and FN3483

1.2 Explanation of Ecosine Max designation

Ecosine Max is part of the new generation of Schaffner passive harmonic filter. Starting from Schaffner Ecosine Evo series, a designation system, which contains 4 sections connected with '-' was introduced. Ecosine Max series, due to its open frame design aimed at cabinet installation, is not offering all options that could be found in Ecosine Evo series but share the same designation system with an X for unavailable options.

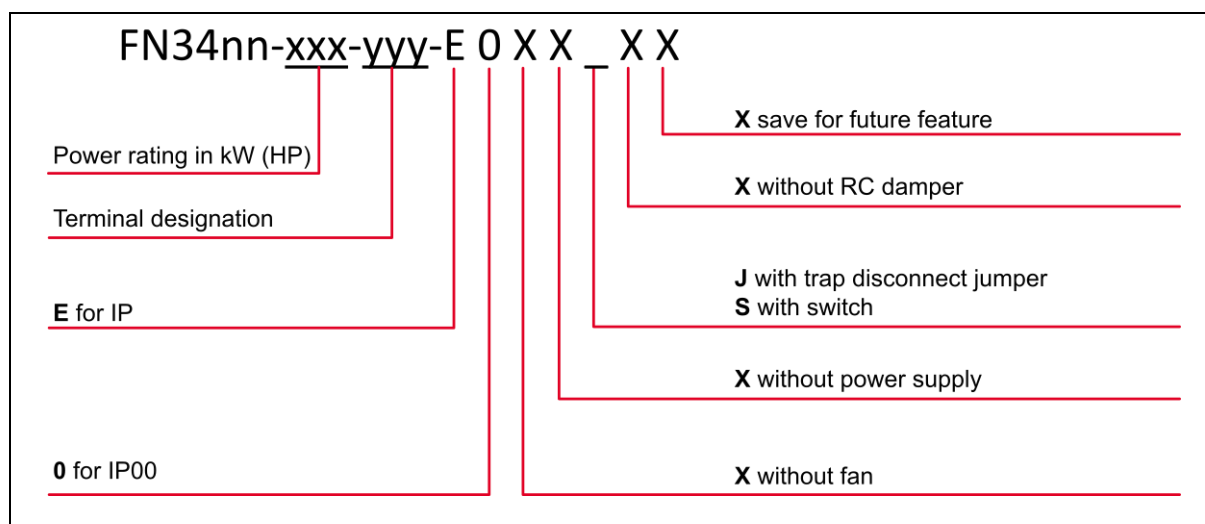

Figure 3 Ecosine Max designation

- | The first part of the designation '**FN34nn-xxx-yyy-_____**' distinguishes between the eight Ecosine Max filter series.

Table 2 operating frequency and nominal voltage per filter type

	FN3470	FN3471	FN3480	FN3481	FN3472	FN3473	FN3482	FN3483
Operating frequency	50 Hz		50 Hz		60 Hz		60 Hz	
Nominal operating voltage	3x 380 to 415 VAC		3x 440 to 480 VAC		3x 380 to 415 VAC		3x 440 to 480 VAC	

- | The second part of the designation '**FN34nn-xxx-yyy-_____**' indicates the **motor drive power rating**, in kW for 50 Hz filters and in HP for 60 Hz filters. Please note that Ecosine Max filters are not using current rating in the designation.
- | The third part of the designation '**FN34nn-xxx-yyy-_____**' indicates the power terminal type. For Ecosine Max all filters are equipped with busbar terminals (-99).
- | [The fourth part of the designation '**FN34nn-xxx-yyy- E0XX_XX**' contains seven slots. This designation format is shared with Ecosine Evo series, however the Ecosine Max series doesn't offer all the options of evo series, the only relevant option is the 5th slot, designating the presence of a switch (S) or a trap disconnect jumper module (J) for installing a switch provided by customer themselves.
- | Schaffner offers Power Quality Simulator **SchaffnerPQS3** (pqs.schaffner.com) to select and verify the most suitable Ecosine Max filter for your application.

Examples of Ecosine Max filter designations:

FN3470-315-99-E0XXSXX: Filter for 50 Hz, 380–415 V AC grid, motor drive power rating 315kW, open frame (IP 00), filter contains trap disconnect switch module. Filter is expected to achieve 5% THDi for drives without DC-link choke, or 3.5% THDi for drives with 4% DC-link choke.

FN3481-400-99-E0XXJXX: Filter for 50 Hz, 440–480 V AC grid, motor drive power rating 400kW, open frame (IP 00), filter contains trap disconnect jumper module. Filter is expected to achieve 8% THDi for drives without DC-link choke, or 5% THDi for drives with 4% DC-link choke.

FN3482-500-99-E0XXSXX: Filter for 60 Hz, 440–480 V AC grid, motor drive power rating 500HP, open frame (IP 00), filter contains trap disconnect switch module. Filter is expected to achieve 5% THDi for drives without DC-link choke, or 3.5% THDi for drives with 4% DC-link choke.

2 Filter selection

Ecosine Max Passive Harmonic Filters need to be carefully selected and configured to enjoy maximum benefits. Schaffner advises to verify the selection by using the Schaffner Power Quality Simulator tool SchaffnerPQS3, available at pqs.schaffner.com.

Step 1: Grid frequency

Determine, whether the system in consideration will be operated in a 50 Hz or 60 Hz electricity grid, and select the corresponding filter series according to the following table:

50 Hz grid	Europe, Middle East, parts of Asia, parts of South America	FN3470/FN3471
		FN3480/FN3481
60 Hz grid	North and Central America, parts of Asia, parts of South America	FN3472/FN3473
		FN3482/FN3483

Note: a 50 Hz filter will not provide satisfying harmonics mitigation in a 60 Hz grid, and vice versa.

Step 2: Grid voltage

Verify that the grid configuration is suitable for standard Ecosine Max Passive Harmonic Filters according to the following table:

50 Hz grid	Nominal voltage 380–415 V AC	TN, TT, IT configuration
50 Hz grid	Nominal voltage 440–480 V AC	TN, TT, IT configuration
60 Hz grid	Nominal voltage 380–415 V AC	TN, TT, IT configuration
60 Hz grid	Nominal voltage 440–480 V AC	TN, TT, IT configuration

Step 3: Rectifier type, presence of DC-link choke in drive

Refer Table 1 for filter performance.

Step 4: Rectifier/Drive input power

The individual filter must be selected with respect to the rectifier/motor drive input power in kW respectively in HP. It is important to match rated filter power as close as possible with the effective input power of the rectifier/drive.

Note that if the rectifier/drive is being operated very close to its rated power, then the filter can be selected by the motor drive's nominal power rating. However, if the drive will be operated e.g. at only 66% of its rated power, then a smaller filter should be selected in order to get maximum harmonics mitigation performance and the optimum in terms of cost, size, and weight. In that case the customer is responsible to ensure that ecosine passive harmonic filter will be operated within specification. This is particularly important in terms of overload.

Please refer to the following examples:

Example 1:

Power line rating: 400 V, 50 Hz

Drive rating: 380–500 V, 50–60 Hz, 355 kW, 727 A, B6-diode rectifier without DC-link choke

Required THDi @ rated power: 5%

Planned rectifier/drive input real power: 355kW (100% of drive rating)

Recommended filter: Type FN3470-355-99

Example 2:

Power line rating: 400 V, 50 Hz

Drive rating: 380–500 V, 50–60 Hz, 355 kW, 559 A, B6-diode rectifier with an 4% DC-link choke

Planned rectifier/drive input real power: 355 kW (100% of drive rating)

Required THDi @ rated power: 5%

Recommended filter: Type FN3471-355-99

Example 3:

Power line rating: 480 V, 50 Hz

Drive rating: 440–480 V, 50–60 Hz, 400 kW, 700 A, B6-diode rectifier without DC-link choke

Planned rectifier/drive input real power: 400kW (100% of drive rating)

Required THDi @ rated power: 10%

Recommended filter: Type FN3481-400-99

Example 4:

Power line rating: 480 V, 60 Hz

Drive rating: 380–500 V, 50–60 Hz, 400 HP, 537 A, diode rectifier

Planned rectifier/drive input real power: 400 HP (100% of drive rating)

Required THDi @ rated power: 10%

Recommended filter: Type FN3483-400-99

Oversizing of passive harmonic filters is not recommended because of the inherent lower harmonic mitigation performance at partial load as well as higher cost, size, and weight.

Please refer to sections 2.1 to 2.4 for proper filter selection.

2.1 Filter selection tables FN3470/FN3471 (50 Hz, 3×380 ... 415 VAC)

Table 3 FN3470 filter selection table for models with circuit breaker

Filter	Rated load power @ 400V /50 Hz [kW]	Motor drive input current [Arms]	Rated filter input current [Arms]	Typical power losses @ 40°C [W]	Circuit breaker rated current [A]	Weight [kg]	Terminal	Frame size
FN3470-250-99-E0XXSXX	250	435	376	3029	250	270	Busbar	S10
FN3470-315-99-E0XXSXX	315	655	475	3295	250	295	Busbar	S10
FN3470-355-99-E0XXSXX	355	727	538	3527	300	320	Busbar	S12
FN3470-400-99-E0XXSXX	400	808	608	4617	400	426	Busbar	L10
FN3470-500-99-E0XXSXX	500	985	766	4475	400	510	Busbar	L12

*Motor drive input current without harmonic filter.

Table 4 FN3470 filter selection table for models with trap disconnect jumper

Filter	Rated load power @ 400V /50 Hz [kW]	Motor drive input current [Arms]	Rated filter input current [Arms]	Typical power losses @ 40°C [W]	Weight [kg]	Terminal	Frame size
FN3470-250-99-E0XXJXX	250	435	376	3029	270	Busbar	S10
FN3470-315-99-E0XXJXX	315	655	475	3295	295	Busbar	S10
FN3470-355-99-E0XXJXX	355	727	538	3527	320	Busbar	S12
FN3470-400-99-E0XXJXX	400	808	608	4617	426	Busbar	L10
FN3470-500-99-E0XXJXX	500	985	766	4475	510	Busbar	L12

*Motor drive input current without harmonic filters.

Table 5 FN3471 filter selection table for models with circuit breaker

Filter	Rated load power @ 400V /50 Hz	Motor drive input current*	Rated filter input current	Required Ldc for 5% THDi**	Typical power losses @ 40°C	Circuit breaker rated current	Weight	Terminal	Frame size
	[kW]	[Arms]	[Arms]	[mH]	[W]	[A]	[kg]		
FN3471-250-99-E0XXSXX	250	435	376	0.082	1974	250	240	Busbar	S08
FN3471-315-99-E0XXSXX	315	655	475	0.065	2226	250	270	Busbar	S08
FN3471-355-99-E0XXSXX	355	727	538	0.058	2346	300	292	Busbar	S08
FN3471-400-99-E0XXSXX	400	808	608	0.051	3501	400	362	Busbar	L08
FN3471-500-99-E0XXSXX	500	985	766	0.041	3195	400	410	Busbar	L08

*Motor drive input current without filter.

**FN3471 filters can be applied for drives with and without Ldc. 8% THDi (@ rated power) is achieved when FN3471 is applied to drives without Ldc, while 5% THDi (@rated power) is achieved when there is a 4% Ldc present in the drive.

Table 6 FN3471 filter selection table for models with trap disconnect jumper

Filter	Rated load power @ 400V /50 Hz	Motor drive input current*	Rated filter input current	Required Ldc for 5% THDi**	Typical power losses @ 40°C	Weight	Terminal	Frame size
	[kW]	[Arms]	[Arms]	[mH]	[W]	[kg]		
FN3471-250-99-E0XXJXX	250	435	376	0.082	1974	240	Busbar	S08
FN3471-315-99-E0XXJXX	315	655	475	0.065	2226	270	Busbar	S08
FN3471-355-99-E0XXJXX	355	727	538	0.058	2346	292	Busbar	S08
FN3471-400-99-E0XXJXX	400	808	608	0.051	3501	362	Busbar	L08
FN3471-500-99-E0XXJXX	500	985	766	0.041	3195	410	Busbar	L08

*Motor drive input current without filter.

**FN3471 filters can be applied for drives with and without Ldc. 8% THDi (@ rated power) is achieved when FN3471 is applied to drives without Ldc, while 5% THDi (@rated power) is achieved when there is a 4% Ldc present in the drive.

2.2 Filter selection table FN3480/FN3481 (50 Hz, 3×440 ... 480 VAC)

Table 7 FN3480 filter selection table for models with circuit breaker

Filter	Rated load power @ 400V [kW]	Motor drive input current [Arms]	Rated filter input current [Arms]	Typical power losses @ 40°C [W]	Circuit breaker rated current [A]	Weight [kg]	Terminal	Frame size
FN3480-315-99-E0XXSXX	315	565	393	3278	250	270	Busbar	S10
FN3480-355-99-E0XXSXX	355	630	442	3343	250	328	Busbar	S10
FN3480-400-99-E0XXSXX	400	701	499	3584	300	366	Busbar	S12
FN3480-500-99-E0XXSXX	500	856	629	4356	400	385	Busbar	L10
FN3480-560-99-E0XXSXX	560	947	705	4536	400	410	Busbar	L12

*Motor drive input current without harmonic filter.

Table 8 FN3480 filter selection table for models with trap disconnect jumper

Filter	Rated load power @ 400V /50 Hz [kW]	Motor drive input current [Arms]	Rated filter input current [Arms]	Typical power losses @ 40°C [W]	Weight [kg]	Terminal	Frame size
FN3480-315-99-E0XXJXX	315	565	393	3278	270	Busbar	S10
FN3480-355-99-E0XXJXX	355	630	442	3343	328	Busbar	S10
FN3480-400-99-E0XXJXX	400	701	499	3584	366	Busbar	S12
FN3480-500-99-E0XXJXX	500	856	629	4356	385	Busbar	L10
FN3480-560-99-E0XXJXX	560	947	705	4536	410	Busbar	L12

*Motor drive input current without harmonic filter.

Table 9 FN3481 filter selection table for models with circuit breaker

Filter	Rated load power @ 400V /50 Hz [kW]	Motor drive input current* [Arms]	Rated filter input current [Arms]	Required Ldc for 5% THDi** [mH]	Typical power losses @ 40°C [W]	Circuit breaker rated current [A]	Weight [kg]	Terminal	Frame size
FN3481-315-99-E0XXSXX	315	564	393	0.094	2223	250	250	Busbar	S08
FN3481-355-99-E0XXSXX	355	630	444	0.083	2274	250	272	Busbar	S08
FN3481-400-99-E0XXSXX	400	701	501	0.074	2403	300	288	Busbar	S08
FN3481-500-99-E0XXSXX	500	856	630	0.059	3240	400	376	Busbar	L08
FN3481-560-99-E0XXSXX	560	947	709	0.053	3256	400	385	Busbar	L08

* Motor drive input current without harmonic filter.

** FN3481 filters can be applied for drives with and without Ldc. 8% THDi (@ rated power) is achieved when FN3481 is applied to drives without Ldc, while 5% THDi (@ rated power) is achieved when there is a 4% Ldc present in the drive.

Table 10 FN3481 filter selection table for models with trap disconnect jumper

Filter	Rated load power @ 400V /50 Hz [kW]	Motor drive input current* [Arms]	Rated filter input current [Arms]	Required Ldc for 5% THDi** [mH]	Typical power losses @ 40°C [W]	Weight [kg]	Terminal	Frame size
FN3481-315-99-E0XXJXX	315	564	393	0.094	2223	250	Busbar	S08
FN3481-355-99-E0XXJXX	355	630	444	0.083	2274	272	Busbar	S08
FN3481-400-99-E0XXJXX	400	701	501	0.074	2403	288	Busbar	S08
FN3481-500-99-E0XXJXX	500	856	630	0.059	3240	376	Busbar	L08
FN3481-560-99-E0XXJXX	560	947	709	0.053	3256	385	Busbar	L08

* Motor drive input current without harmonic filter.

** FN3481 filters can be applied for drives with and without Ldc. 8% THDi (@ rated power) is achieved when FN3481 is applied to drives without Ldc, while 5% THDi (@ rated power) is achieved when there is a 4% Ldc present in the drive.

2.3 Filter selection table FN3472/FN3473 (60 Hz, 3×380 ... 415 VAC)

Table 11 FN3472 filter selection table for models with circuit breaker

Filter	Rated load power @ 400V /50 Hz [kW]	Motor drive input current [Arms]	Rated filter input current [Arms]	Typical power losses @ 40°C [W]	Circuit breaker rated current [A]	Weight [kg]	Terminal	Frame size
FN3472-280-99-E0XSXX	209	280	472	327	2832	200	245	540
FN3472-315-99-E0XSXX	235	315	537	375	3200	200	270	595
FN3472-355-99-E0XSXX	265	355	595	420	3451	250	295	650
FN3472-400-99-E0XSXX	300	400	656	469	3404	250	320	705
FN3472-480-99-E0XSXX	358	480	773	563	4173	300	385	849

*Motor drive input current without harmonic filter.

Table 12 FN3472 filter selection table for models with trap disconnect jumper

Filter	Rated load power @ 400V /50 Hz [kW]	Motor drive input current [Arms]	Rated filter input current [Arms]	Typical power losses @ 40°C [W]	Weight [kg]	Terminal	Frame size
FN3472-280-99-E0XJXX	209	280	472	327	2832	245	540
FN3472-315-99-E0XJXX	235	315	537	375	3200	270	595
FN3472-355-99-E0XJXX	265	355	595	420	3451	295	650
FN3472-400-99-E0XJXX	300	400	656	469	3404	320	705
FN3472-480-99-E0XJXX	358	480	773	563	4173	385	849

*Motor drive input current without harmonic filter.

Table 13 FN3473 filter selection table for models with circuit breaker

Filter	Rated load power @ 400V /50 Hz	Motor drive input current*	Rated filter input current	Required Ldc for 5% THDi**	Typical power losses @ 40°C	Circuit breaker rated current	Weight	Terminal	Frame size
	[kW]	[Arms]	[Arms]	[mH]	[W]	[A]	[kg]		
FN3473-280-99-E0XSXX	209	280	472	325	0.074	2085	200	220	485
FN3473-315-99-E0XSXX	235	315	537	374	0.066	2145	200	245	540
FN3473-355-99-E0XSXX	265	355	595	418	0.058	2382	250	270	595
FN3473-400-99-E0XSXX	300	400	656	467	0.052	2223	250	295	650
FN3473-480-99-E0XSXX	358	480	772	561	0.044	3057	300	360	794

* Motor drive input current without harmonic filter.

** FN3473 filters can be applied for drives with and without Ldc. 8% THDi (@ rated power) is achieved when FN3473 is applied to drives without Ldc, while 5% THDi (@ rated power) is achieved when there is a 4% Ldc present in the drive.

Table 14 FN3473 filter selection table for models with trap disconnect jumper

Filter	Rated load power @ 400V /50 Hz	Motor drive input current*	Rated filter input current	Required Ldc for 5% THDi**	Typical power losses @ 40°C	Weight	Terminal	Frame size
	[kW]	[Arms]	[Arms]	[mH]	[W]	[kg]		
FN3473-280-99-E0XXJXX	209	280	472	325	0.074	2085	220	485
FN3473-315-99-E0XXJXX	235	315	537	374	0.066	2145	245	540
FN3473-355-99-E0XXJXX	265	355	595	418	0.058	2382	270	595
FN3473-400-99-E0XXJXX	300	400	656	467	0.052	2223	295	650
FN3473-480-99-E0XXJXX	358	480	772	561	0.044	3057	360	794

* Motor drive input current without harmonic filter.

** FN3473 filters can be applied for drives with and without Ldc. 8% THDi (@ rated power) is achieved when FN3473 is applied to drives without Ldc, while 5% THDi (@ rated power) is achieved when there is a 4% Ldc present in the drive.

2.4 Filter selection table FN3482/FN3483 (60 Hz, 3×440 ... 480 VAC)

Table 15 FN3482 filter selection table for models with circuit breaker

Filter	Rated load power@ 480 V/60 Hz		Motor drive input current*	Rated filter input current	Typical power losses @ 40°C	Circuit breaker rated current	Weight		Terminal	Frame size
	[kW]	[HP]					[kg]	[lbs]		
FN3482-350-99-E0XXSXX	260	350	472	327	2832	200	245	540	Busbar	S10
FN3482-400-99-E0XXSXX	300	400	537	375	3200	200	270	595	Busbar	S10
FN3482-450-99-E0XXSXX	335	450	595	420	3451	250	295	650	Busbar	S10
FN3482-500-99-E0XXSXX	370	500	656	467	3404	250	320	705	Busbar	S12
FN3482-600-99-E0XXSXX	450	600	773	563	4173	300	385	849	Busbar	L10

*Motor drive input current without harmonic filter.

Table 16 FN3482 filter selection table for models with trap disconnect jumper

Filter	Rated load power@ 480 V/60 Hz		Motor drive input current*	Rated filter input current	Typical power losses @ 40°C	Weight		Terminal	Frame size
	[kW]	[HP]				[kg]	[lbs]		
FN3482-350-99-E0XXJXX	260	350	472	327	2832	245	540	Busbar	S10
FN3482-400-99-E0XXJXX	300	400	537	375	3200	270	595	Busbar	S10
FN3482-450-99-E0XXJXX	335	450	595	420	3451	295	650	Busbar	S10
FN3482-500-99-E0XXJXX	370	500	656	467	3404	320	705	Busbar	S12
FN3482-600-99-E0XXJXX	450	600	773	563	4173	385	849	Busbar	L10

*Motor drive input current without harmonic filter.

Table 17 FN3483 filter selection table for models with circuit breaker

Filter	Rated load power @ 480 V/60 Hz		Motor drive input current*	Rated filter input current	Required Ldc for 5% THDi**	Typical power losses @ 40°C	Circuit breaker rated current	Weight		Terminal	Frame size
	[kw]	[HP]						[kg]	[lbs]		
FN3483-350-99- E0XXSXX	260	350	472	325	0.095	2085	200	220	485	Busbar	S08
FN3483-400-99- E0XXSXX	300	400	537	374	0.082	2145	200	245	540	Busbar	S08
FN3483-450-99- E0XXSXX	335	450	595	418	0.074	2382	250	270	595	Busbar	S08
FN3483-500-99- E0XXSXX	370	500	656	467	0.066	2223	250	295	650	Busbar	S08
FN3483-600-99- E0XXSXX	450	600	772	561	0.055	3057	300	360	794	Busbar	L08

*Motor drive input current without harmonic filter.

** FN3483 filters can be applied for drives with and without Ldc. 8% THDi (@ rated power) is achieved when FN3483 is applied to drives without Ldc, while 5% THDi (@ rated power) is achieved when there is a 4% Ldc present in the drive.

Table 18 FN3483 filter selection table for models with trap disconnect jumper

Filter	Rated load power @ 480 V/60 Hz		Motor drive input current*	Rated filter input current	Required Ldc for 5% THDi**	Typical power losses @ 40°C	Weight		Terminal	Frame size
	[kw]	[HP]					[kg]	[lbs]		
FN3483-350-99-E0XXJXX	260	350	472	325	0.095	2085	220	485	Busbar	S08
FN3483-400-99-E0XXJXX	300	400	537	374	0.082	2145	245	540	Busbar	S08
FN3483-450-99-E0XXJXX	335	450	595	418	0.074	2382	270	595	Busbar	S08
FN3483-500-99-E0XXJXX	370	500	656	467	0.066	2223	295	650	Busbar	S08
FN3483-600-99-E0XXJXX	450	600	772	561	0.055	3057	360	794	Busbar	L08

*Motor drive input current without harmonic filter.

** FN3483 filters can be applied for drives with and without Ldc. 8% THDi (@ rated power) is achieved when FN3483 is applied to drives without Ldc, while 5% THDi (@ rated power) is achieved when there is a 4% Ldc present in the drive.

3 Filter description

3.1 General electrical specifications FN3470/FN3471 (50 Hz filters)

Nominal operating voltage:	3x 380 to 415 V AC
Voltage tolerance range:	3x 342 to 457 V AC
Operating frequency:	50 Hz ±1 Hz
Network:	TN, TT, IT
Nominal motor drive input power rating:	250 to 500kW
Total harmonic current distortion THDi: ²⁾	<5% @ rated power ¹⁾
Total demand distortion TDD: ²⁾	According to IEEE 519
Efficiency:	>99% @ nominal line voltage and power
Drive dc-link voltage:	-5% ~ +10% nominal V _{DC}
High potential test voltage: ³⁾	P → E 2520 VAC (1s)
SCCR: ⁴⁾	100kA, fuses according UL class J or L
Protection category:	IP 00
Overvoltage category (acc. IEC 60664-1)	III
Pollution degree:	PD3 (according to standard IEC 60664-1)
Climatic class:	25/070/21 (IEC60068-1)
Cooling:	External cooling ⁵⁾
Overload capability:	1.6x rated current for 1 minute, once per hour
Capacitive current @ no load:	<20% of rated input current, at 400 V AC
Ambient temperature range:	-25°C to +40°C fully operational +40°C to +70°C derated operation ⁶⁾ -25°C to +80°C transportation and storage
Flammability class:	UL 94 V0
Insulation class of magnetic components:	200(N) acc. UL 1446
Design corresponding to:	Filter: UL/IEC 61800-5-1, EN 61800-5-1 Chokes: EN 60076-6
MTBF @ 40°C/400 V (Mil-HB-217F):	>200,000 hours
MTTR:	<60 minutes (capacitor modules)
Lifetime (calculated):	≥10 years (with maintenance)
Safety monitor output signal:	Thermal switch NC 180° C (UL-approved) to detect overload of chokes

¹⁾ Refer to Table 1

²⁾ System requirements: THVD <2%, line voltage unbalance <1%

Conditions: line impedance <3%

³⁾ Repetitive tests to be performed at max. 80% of above levels, for 2 seconds.

⁴⁾ External UL-rated fuses required.

⁵⁾ Please check the inlet air flow required for cooling in section 3.8

⁶⁾ $I_{derated} = I_{nominal} \times \sqrt{((70^{\circ}\text{C} - T_{amb})/30^{\circ}\text{C})}$

3.2 General electrical specifications FN3480/FN3481 (50 Hz filters)

Nominal operating voltage:	3x 440 to 480 V AC
Voltage tolerance range:	3x 396 to 528 V AC
Operating frequency:	50 Hz ±1 Hz
Network:	TN, TT, IT
Nominal motor drive input power rating:	315 to 560kW
Total harmonic current distortion THDi: ²⁾	<5% @ rated power ¹⁾
Total demand distortion TDD: ²⁾	According to IEEE 519
Efficiency:	>99% @ nominal line voltage and power
Drive dc-link voltage:	-5% ~ +10% nominal V _{DC}
High potential test voltage: ³⁾	P → E 2520 VAC (1s)
SCCR: ⁴⁾	100kA, fuses according UL class J or L
Protection category:	IP 00
Overvoltage category (acc. IEC 60664-1)	III
Pollution degree:	PD3 (according to standard IEC 60664-1)
Climatic class:	25/070/21 (IEC60068-1)
Cooling:	External cooling ⁵⁾
Overload capability:	1.6x rated current for 1 minute, once per hour
Capacitive current @ no load:	<20% of rated input current, at 400 V AC
Ambient temperature range:	-25°C to +40°C fully operational +40°C to +70°C derated operation ⁶⁾ -25°C to +80°C transportation and storage
Flammability class:	UL 94 V0
Insulation class of magnetic components:	200(N) acc. UL 1446
Design corresponding to:	Filter: UL/IEC 61800-5-1, EN 61800-5-1 Chokes: EN 60076-6
MTBF @ 40°C/400 V (Mil-HB-217F):	>200,000 hours
MTTR:	<60 minutes (capacitor modules)
Lifetime (calculated):	≥10 years (with maintenance)
Safety monitor output signal:	Thermal switch NC 180° C (UL-approved) to detect overload of chokes

¹⁾ Refer to Table 1

²⁾ System requirements: THVD <2%, line voltage unbalance <1%
Conditions: line impedance <3%

³⁾ Repetitive tests to be performed at max. 80% of above levels, for 2 seconds.

⁴⁾ External UL-rated fuses required.

⁵⁾ Please check the inlet air flow required for cooling in section 3.8

⁶⁾ $I_{derated} = I_{nominal} \times \sqrt{((70^{\circ}\text{C} - T_{amb})/30^{\circ}\text{C})}$

3.3 General electrical specifications FN3472/FN3473 (60 Hz filters)

Nominal operating voltage:	3x 380 to 415 V AC
Voltage tolerance range:	3x 342 to 456 V AC
Operating frequency:	60 Hz ±1 Hz
Network:	TN, TT, IT
Nominal motor drive input power rating:	280 to 480 HP (209 to 358 kW)
Total harmonic current distortion THDi: ²⁾	<5% @ rated power ¹⁾
Total demand distortion TDD: ²⁾	According to IEEE 519
Efficiency:	>99% @ nominal line voltage and power
Drive dc-link voltage:	-5% ~ +10% nominal V _{DC}
High potential test voltage: ³⁾	P → E 2520 VAC (1s)
SCCR: ⁴⁾	100kA, fuses according UL class J or L
Protection category:	IP 00
Overvoltage category (acc. IEC 60664-1)	III
Pollution degree:	PD3 (according to standard IEC 60664-1)
Climatic class:	25/070/21 (IEC60068-1)
Cooling:	External cooling ⁵⁾
Overload capability:	1.6x rated current for 1 minute, once per hour
Capacitive current @ no load:	<20% of rated input current, at 400 V AC
Ambient temperature range:	-25°C to +40°C fully operational +40°C to +70°C derated operation ⁶⁾ -25°C to +80°C transportation and storage
Flammability class:	UL 94 V0
Insulation class of magnetic components:	200(N) acc. UL 1446
Design corresponding to:	Filter: UL/IEC 61800-5-1, EN 61800-5-1 Chokes: EN 60076-6
MTBF @ 40°C/400 V (Mil-HB-217F):	>200,000 hours
MTTR:	<60 minutes (capacitor modules)
Lifetime (calculated):	≥10 years (with maintenance)
Safety monitor output signal:	Thermal switch NC 180° C (UL-approved) to detect overload of chokes

¹⁾ Refer to Table 1

²⁾ System requirements: THVD <2%, line voltage unbalance <1%
Conditions: line impedance <3%

³⁾ Repetitive tests to be performed at max. 80% of above levels, for 2 seconds.

⁴⁾ External UL-rated fuses required.

⁵⁾ Please check the inlet air flow required for cooling in section 3.8

⁶⁾ $I_{derated} = I_{nominal} \times \sqrt{((70^{\circ}\text{C} - T_{amb})/30^{\circ}\text{C})}$

3.4 General electrical specifications FN3482/FN3483 (60 Hz filters)

Nominal operating voltage:	3x 440 to 480 V AC
Voltage tolerance range:	3x 396 to 528 V AC
Operating frequency:	60 Hz ±1 Hz
Network:	TN, TT, IT
Nominal motor drive input power rating:	350 to 600 HP (260 to 447 kW)
Total harmonic current distortion THDi: ²⁾	<5% @ rated power ¹⁾
Total demand distortion TDD: ²⁾	According to IEEE 519
Efficiency:	>99% @ nominal line voltage and power
Drive dc-link voltage:	-5% ~ +10% nominal V _{DC}
High potential test voltage: ³⁾	P → E 2520 VAC (1s)
SCCR: ⁴⁾	100kA, fuses according UL class J or L
Protection category:	IP 00
Overvoltage category (acc. IEC 60664-1)	III
Pollution degree:	PD3 (according to standard IEC 60664-1)
Climatic class:	25/070/21 (IEC60068-1)
Cooling:	External cooling ⁵⁾
Overload capability:	1.6x rated current for 1 minute, once per hour
Capacitive current @ no load:	<20% of rated input current, at 400 V AC
Ambient temperature range:	-25°C to +40°C fully operational +40°C to +70°C derated operation ⁶⁾ -25°C to +80°C transportation and storage
Flammability class:	UL 94 V0
Insulation class of magnetic components:	200(N) acc. UL 1446
Design corresponding to:	Filter: UL/IEC 61800-5-1, EN 61800-5-1 Chokes: EN 60076-6
MTBF @ 40°C/400 V (Mil-HB-217F):	>200,000 hours
MTTR:	<60 minutes (capacitor modules)
Lifetime (calculated):	≥10 years (with maintenance)
Safety monitor output signal:	Thermal switch NC 180° C (UL-approved) to detect overload of chokes

¹⁾ Refer to Table 1

²⁾ System requirements: THVD <2%, line voltage unbalance <1%
Conditions: line impedance <3%

³⁾ Repetitive tests to be performed at max. 80% of above levels, for 2 seconds.

⁴⁾ External UL-rated fuses required.

⁵⁾ Please check the inlet air flow required for cooling in section 3.8

⁶⁾ $I_{\text{derated}} = I_{\text{nominal}} \times \sqrt{((70^{\circ}\text{C} - T_{\text{amb}}) / 30^{\circ}\text{C})}$

3.5 Additional electrical specifications

Ecosine Max Passive Harmonic Filters general electrical specifications refer to operating altitudes up to 2000m (6600ft) above sea level.

Operation between 2000m and 4000m (6600ft and 13123ft) requires a derating for clearance and current.

3.5.1 Clearance derating by altitude

Table 19 Altitude correction factors for clearances (extract from table A.2 in IEC 60664-1)

Altitude [m]	Normal barometric pressure	Multiplication factor for clearances
[m]	[kPa]	
2'000	80.0	1.00
3'000	70.0	1.14
4'000	62.0	1.29

3.5.2 Current derating by altitude

The current derating is the factor to which the nominal current needs to be multiplied. A simplified equation can be defined as function of ΔH ($H - 2000$). This equation is valid for H up to 4000 meters ($\Delta H = 2000$ m).

$$\text{Current derating } [I_n^{-1}] = -5 * 10^{-5} * \Delta H + 0.9937$$

Example: at an altitude of 3'500m, we get $\Delta H = 1'500$ m and the current derating = 0.9187. A filter with a rated current of 100A can only be used up to 91.87A.

Remark: Do not use Ecosine Max Passive Harmonic Filters in altitudes above 4000m without consulting Schaffner first.

3.6 Cable cross-section requirement

3.6.1 Power terminals

All power terminal of Ecosine Max filters are busbar connection, with designation -99.

The cable cross-section must be selected according to the rated filter input current, the maximum current, the environment and other special requirements of the application. It should be either a stranded copper wire cable with a temperature rating of $\geq 75^\circ\text{C}$ or higher or a busbar not smaller than the terminal dimensions of the filter. Recommended cable cross-section is given in Table 20, busbar terminal dimensions are given in Figure 4. The customer is fully responsible to define the most appropriate conductor type according to the application and ensure a proper connection of the filter.

Table 20 Cable cross-section recommendation

Filter	Power Rating	Line Current [A]	Voltage [V]	Freq. [Hz]	Terminal Line Busbar	Terminal Load Busbar	Frame Size	Min. recommended cable cross-section per phase	
FN3470-250-99	250 kW	376	400	50	B	B	S10	2x 150 mm ²	2x 250 kcmil
FN3470-315-99	315 kW	475	400	50	D	F	S10	2x 185 mm ²	2x 350 kcmil
FN3470-355-99	355 kW	538	400	50	E	G	S12	2x 300 mm ²	2x 500 kcmil
FN3470-400-99	400 kW	608	400	50	F	G	L10	2x 300 mm ²	2x 500 kcmil
FN3470-500-99	500 kW	766	400	50	F	G	L12	3x 240 mm ²	2x 800 kcmil
FN3471-250-99	250 kW	376	400	50	B	B	S08	2x 150 mm ²	2x 250 kcmil
FN3471-315-99	315 kW	475	400	50	D	F	S08	2x 185 mm ²	2x 350 kcmil
FN3471-355-99	355 kW	538	400	50	E	F	S08	2x 300 mm ²	2x 500 kcmil
FN3471-400-99	400 kW	608	400	50	F	F	L08	2x 300 mm ²	2x 500 kcmil
FN3471-500-99	500 kW	766	400	50	F	F	L08	3x 240 mm ²	2x 800 kcmil
FN3480-315-99	315 kW	393	480	50	B	B	S10	2x 150 mm ²	2x 250 kcmil
FN3480-355-99	355 kW	444	480	50	D	F	S10	2x 185 mm ²	2x 300 kcmil
FN3480-400-99	400 kW	501	480	50	E	G	S12	2x 240 mm ²	2x 400 kcmil
FN3480-500-99	500 kW	630	480	50	F	G	L10	3x 185 mm ²	2x 600 kcmil
FN3480-560-99	560 kW	709	480	50	F	G	L12	3x 185 mm ²	2x 700 kcmil
FN3481-315-99	315 kW	393	480	50	B	B	S08	2x 150 mm ²	2x 250 kcmil
FN3481-355-99	355 kW	444	480	50	D	F	S08	2x 185 mm ²	2x 300 kcmil
FN3481-400-99	400 kW	501	480	50	E	F	S08	2x 240 mm ²	2x 400 kcmil
FN3481-500-99	500 kW	630	480	50	F	F	L08	3x 185 mm ²	2x 600 kcmil
FN3481-560-99	560 kW	709	480	50	F	F	L08	3x 185 mm ²	2x 700kcmil
FN3482-350-99	350 HP	325	480	60	A	B	S10	2x 120 mm ²	2x 4/0 AWG
FN3482-400-99	400 HP	374	480	60	C	B	S10	2x 150 mm ²	2x 250 kcmil
FN3482-450-99	450 HP	418	480	60	B	F	S10	2x 185 mm ²	2x 300 kcmil
FN3482-500-99	500 HP	475	480	60	D	G	S12	2x 185 mm ²	2x 350 kcmil
FN3482-600-99	600 HP	561	480	60	E	G	L10	2x 300 mm ²	2x 500 kcmil
FN3483-350-99	350 HP	325	480	60	A	B	S08	2x 120 mm ²	2x 4/0 AWG
FN3483-400-99	400 HP	374	480	60	C	F	S08	2x 150 mm ²	2x 250 kcmil
FN3483-450-99	450 HP	418	480	60	B	B	S08	2x 185 mm ²	2x 300 kcmil
FN3483-500-99	500 HP	475	480	60	D	F	S08	2x 185 mm ²	2x 350 kcmil
FN3483-600-99	600 HP	561	480	60	E	F	L08	2x 300 mm ²	2x 500 kcmil
FN3472-280-99	280 HP	325	380	60	A	B	S10	2x 120 mm ²	2x 4/0 AWG
FN3472-315-99	315 HP	374	380	60	C	B	S10	2x 150 mm ²	2x 250 kcmil
FN3472-355-99	355 HP	418	380	60	B	F	S10	2x 185 mm ²	2x 300 kcmil
FN3472-400-99	400 HP	475	380	60	D	G	S12	2x 185 mm ²	2x 350 kcmil
FN3472-480-99	480 HP	561	380	60	E	G	L10	2x 300 mm ²	2x 500 kcmil
FN3473-280-99	280 HP	325	380	60	A	B	S08	2x 120 mm ²	2x 4/0 AWG
FN3473-315-99	315 HP	374	380	60	C	F	S08	2x 150 mm ²	2x 250 kcmil
FN3473-355-99	355 HP	418	380	60	B	B	S08	2x 185 mm ²	2x 300 kcmil
FN3473-400-99	400 HP	475	380	60	D	F	S08	2x 185 mm ²	2x 350 kcmil
FN3473-480-99	480 HP	561	380	60	E	F	L08	2x 300 mm ²	2x 500 kcmil

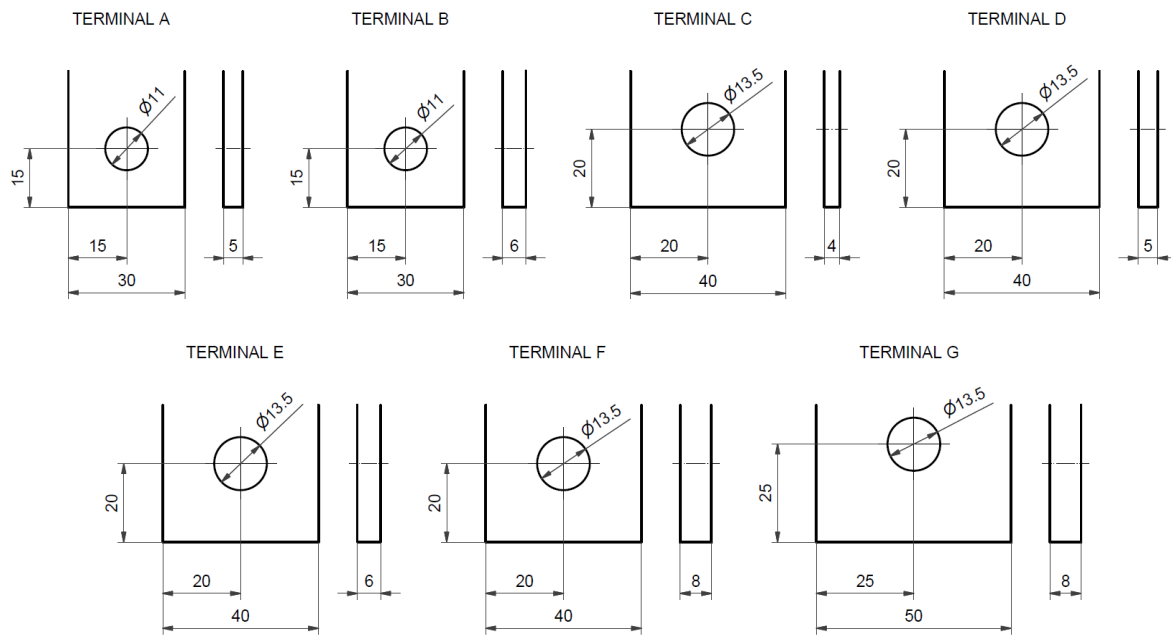

Figure 4 Drawing of different terminal dimensions (according to Table 20)

3.6.2 Trap disconnect jumper terminals

Cable cross section recommended for connection to the trap disconnect jumper terminals (only for configuration with this option):

Table 21 recommended and maximum cable cross section for the trap disconnect jumper terminals

Filter	Minimum recommended cable cross section [mm ²]	Maximum cable cross section [mm ²]	Minimum recommended cable cross section USCS	Maximum cable cross section USCS
FN3470-250-99 FN3471-250-99 FN3480-315-99 FN3481-315-99 FN3482-350-99 FN3482-400-99 FN3482-450-99 FN3483-350-99 FN3483-400-99 FN3483-450-99	50	240	AWG 1/0 (0)	500kcmil
FN3470-315-99 FN3470-355-99 FN3471-315-99 FN3471-355-99 FN3480-355-99 FN3480-400-99 FN3481-355-99 FN3481-400-99 FN3482-500-99 FN3482-600-99 FN3483-500-99 FN3483-600-99	70	240	AWG 3/0 (000)	500kcmil
FN3470-400-99 FN3470-500-99 FN3471-400-99 FN3471-500-99 FN3480-500-99 FN3480-560-99 FN3481-500-99 FN3481-560-99	95	240	AWG 4/0 (0000)	500kcmil

Stripped length 29.5±0.5mm / 1.16±0.02in with ring cable lugs crimped

3.6.3 Auxiliary terminals

Recommended cable cross section for connection to the AS-AS' and TS-TS' auxiliary terminal:

From 0.5mm² / AWG 20 up to 4mm² / AWG 12

Stripped length 10.5±0.5mm / 0.41±0.02in

3.7 Earth terminals screw and torque

Table 22 earth terminals

Earth (PE)	Screw thread	Screw torque value	
		[Nm]	[lbs.in]
S08-L12	M12	20-25	177-221

3.8 Thermal protection switch specifications

One choke of each type is equipped with a thermal protection switch (temperature switch). The 3 switches are connected in series to the auxiliary terminal TS-TS'. If the temperature switch reaches the nominal switching temperature (NST), the switch will open.

Table 23 thermal protection switch specifications

Contact type	Normally closed (NC)
Nominal switching temperature (NST)	180°C
Resetting temperature (RST)	145°C (indication only)
Operating voltage	Up to 250V AC
Rated current AC Inom	2.5A $\cos\phi = 1.0$ 1.6A $\cos\phi = 0.6$ 1.8A $\cos\phi = 0.4-0.5$

3.9 Cabinet specifications

The complete Ecosine Max series has been type-tested and qualified using reference standard cabinets from the manufacturer Rittal, series VX25. Schaffner recommend using the reference cabinet from Rittal series VX25 matching the filter size selected. The filter can be integrated in any standard or customized cabinet according to the same specifications as the reference cabinets. Exact parts number of the reference cabinet are listed in Table 24. Usage of a cabinet that is not according to these specifications, especially any deviations from the cooling requirement and air inlet configuration (see section 3.10) might require additional validation from the customer. Schaffner is not reliable for any deviations in the filter specifications resulting from improper cabinet integration.

Table 24 Part numbers of the reference cabinets from Rittal VX25

	Cabinet 800mm	Cabinet 1000mm	Cabinet 1200mm
Baying enclosure system VX25 Basic enclosure	8806.000	8006.000	8206.000
Support Rail 48x26mm	8617.810	8617.820	8617.830
Roof-mounted fan 1'000m/h	3140.500	3140.500	3140.500
Outlet filter Standard 323 x 323 x 25 mm	3243.200	3243.200	3243.200
Outlet filter Standard 255 x 255 x 25 mm	2x 3240.200	2x 3240.200	2x 3240.200
Side panel, screw-fastened, sheet steel for VX	8106.245	8106.245	8106.245
Base corner piece with base cover, front and rear, 100 mm for VX	8640.033	8640.033	8640.033
Base corner piece with base cover, front and rear, optimized design, 100 mm for VX	8640.003	8640.005	8640.007

3.10 Cooling requirement

It must be ensured that the environmental temperature is kept below 40°C with appropriate thermal management (e.g. cabinet cooling). Filter operation in environments with higher temperatures requires a temperature derating.

External air flow is required in all configurations. The minimum air flow required for all filters can be found in Table 25. It is recommended to have the active cooling fans located at the top of the cabinet and air inlet located according to Figure 5 and Table 26.

Table 25 Air flow required for cooling

Frame size	[m3/h]	Min air volume* CFM [ft3/min]
S08, L08	1069	629
S10, L10	1069	629
S12, L12	1069	629

*External air flow required for filter configurations without embedded ventilation.

Recommended installation on top of cabinet

Note: The required inlet air flow must be provided to guarantee normal operation of the filter. Insufficient inlet air flow or blocking of air channel might cause overheating of filter components.

All Ecosine Max Passive Harmonic Filters have been tested and qualified with cabinet design, presented in the following. The fan configuration below is recommended, however not mandatory if the inlet air flow can be ensured otherwise.

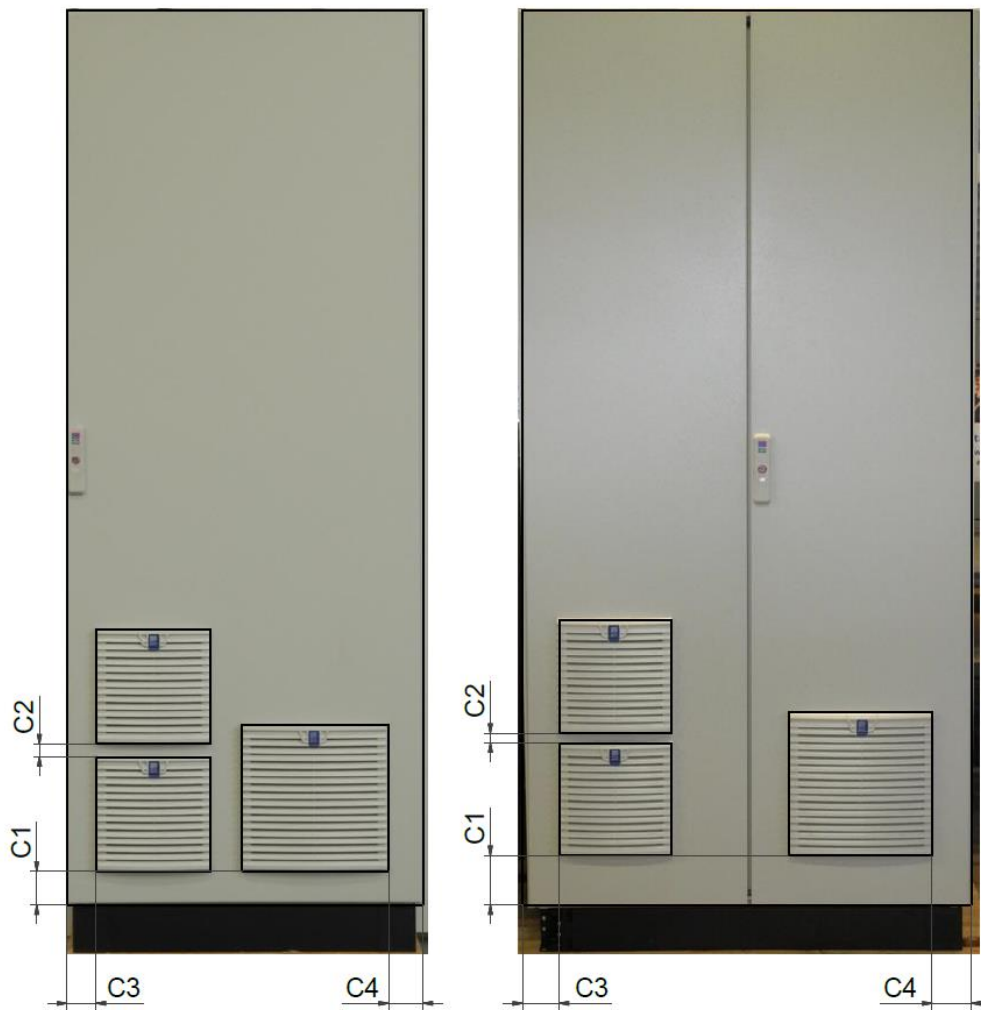

Figure 5 Reference cabinet with recommended air inlet placement

Table 26 Dimensions for the recommended air inlet placement

Dimension	C1	C2	C3	C4
Cabinet 800mm	70	20	70	70
Cabinet 1000mm	120	20	700	80
Cabinet 1200mm	120	20	700	130

3.10.1 Additional requirement for cooling

- To allow significant air flow, the fine dust filter foam needs to be removed from the air inlet.
- Cable entry at the bottom and back of the cabinet should stay open (no use of tight cable entry system if allowed). Recommended opening is visible in Figure 6 to Figure 8.



Figure 6 opening at the bottom and back of the cabinet (front view)



Figure 7 opening at the bottom of the cabinet (top view from inside). About 1/3 remain open.



Figure 8 opening at the back of the cabinet. Base plinth should stay open for cables entry and cooling.

3.11 Mechanical frame sizes

All Ecosine Max Passive Harmonic Filters are realized with 6 frame sizes, S08/S10/S12 and L08/L10/L12. Dimensions and footprint are provided in section 3.12.

Ecosine Max Passive Harmonic Filters are IP00 and external air cooling is needed, details are provided in section 3.8. The overview of all frame sizes is shown in Figure 9.

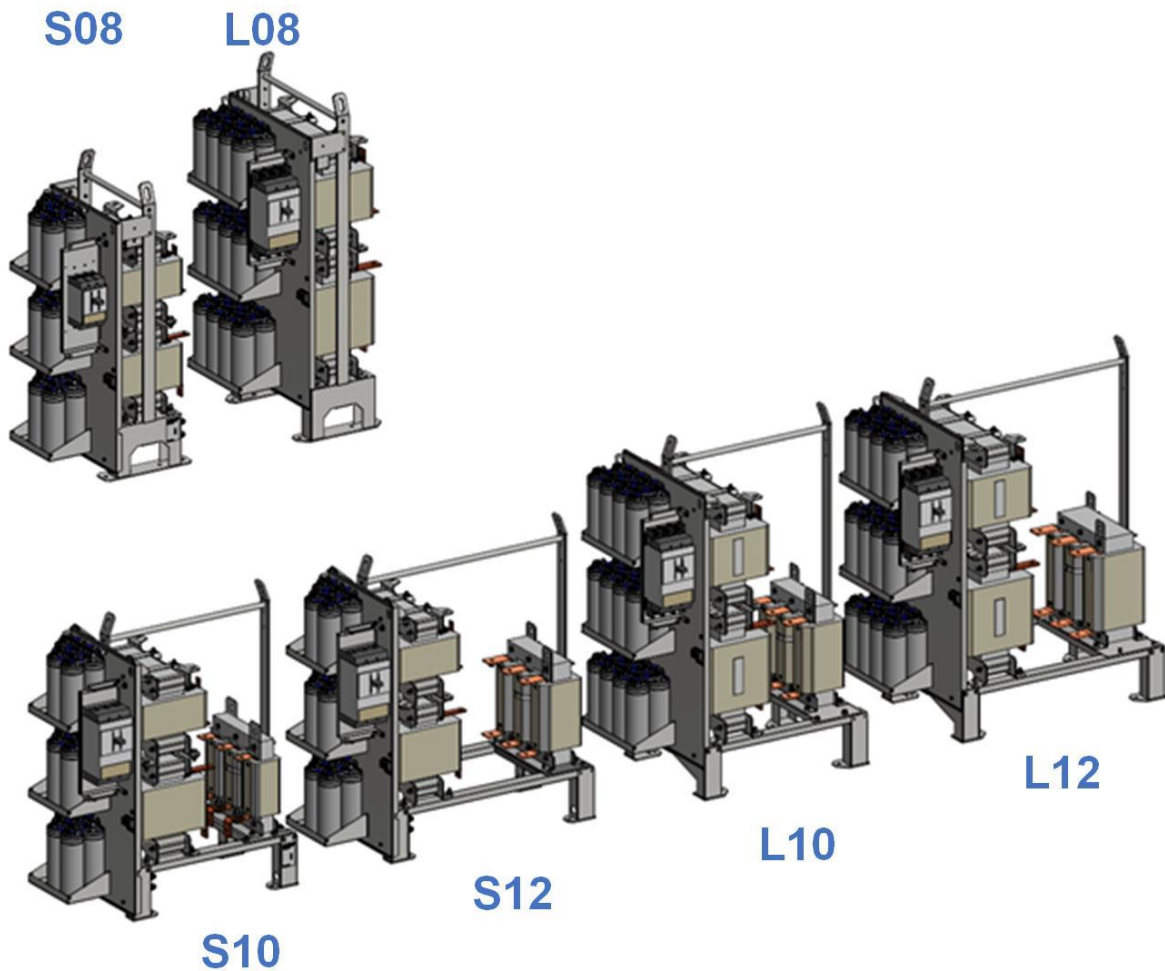

Figure 9 Overview of all Ecosine Max Passive Harmonic Filters frame sizes

3.12 Ecosine Max Passive Harmonic Filters footprint

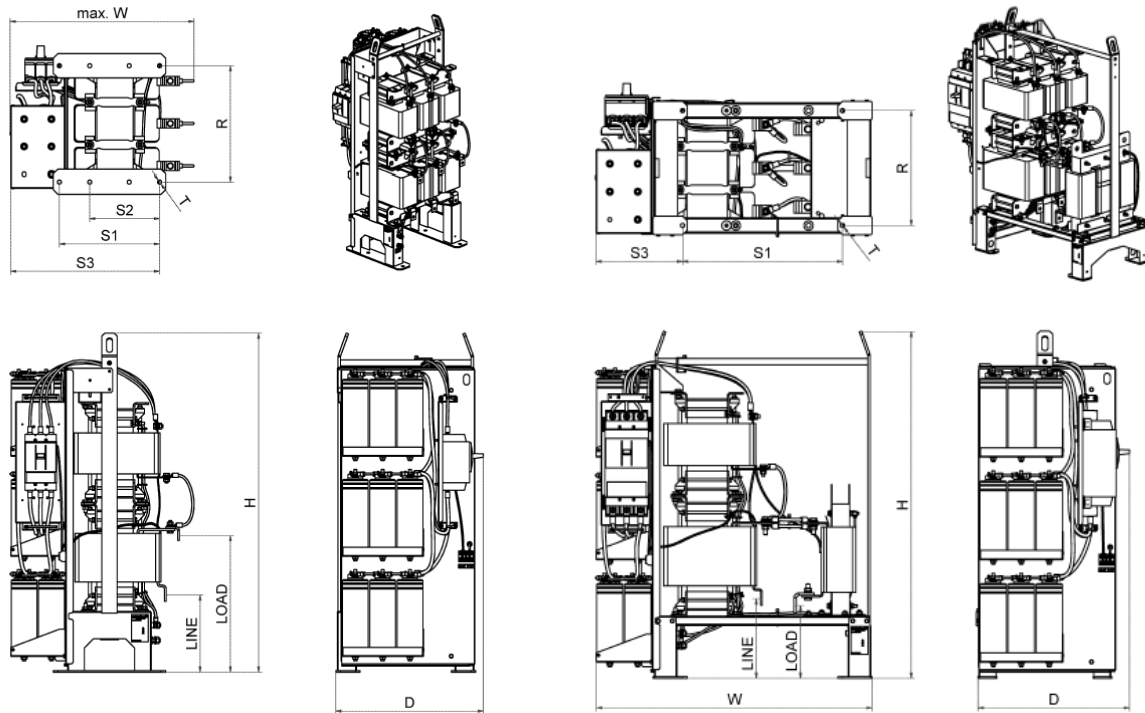

Figure 10 Mechanical data of FN3471/73/81/83 with S option (switch integrated).

Figure 11 Mechanical data of FN3470/72/80/82 with S option (switch integrated)

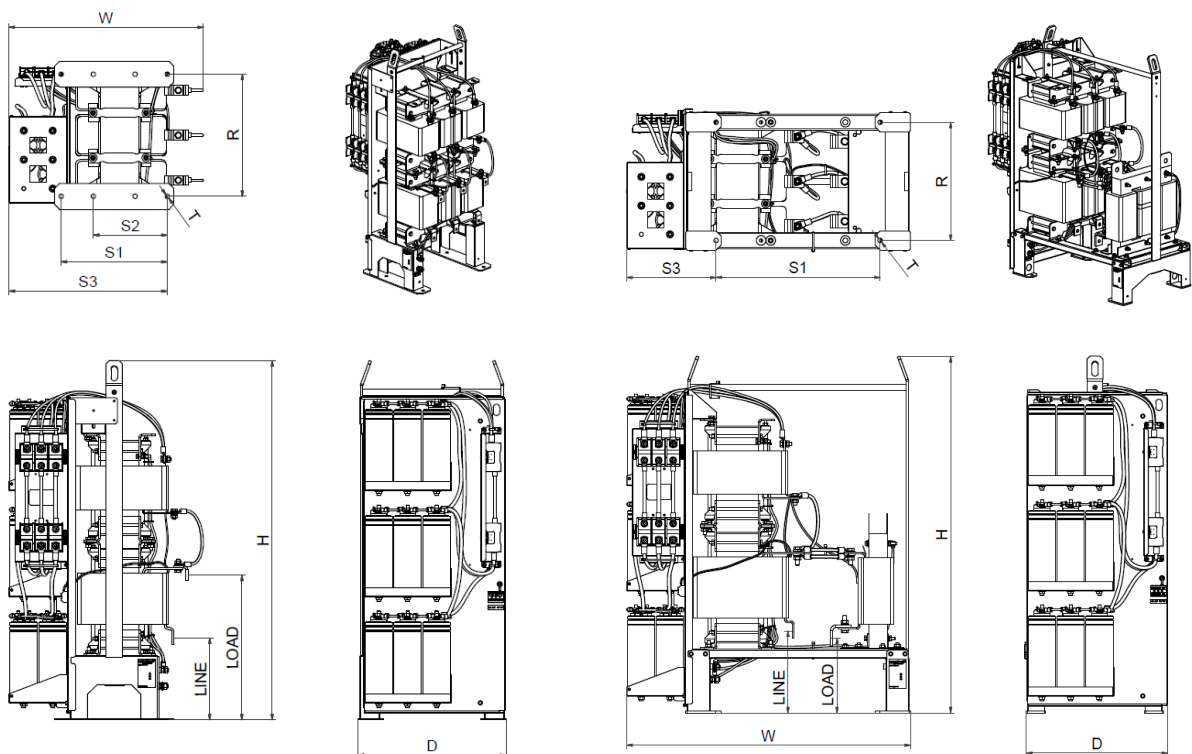

Figure 12 Mechanical data of FN3471/73/81/83 with J option (Trap Disconnect Terminals).

Figure 13 Mechanical data of FN3470/72/80/82 with J option (Trap Disconnect Terminals).

Table 27 Dimensions of all frame sizes in mm

Frame size	W	D	H	R	S1	S2	S3	T	LINE	LOAD	Recommended cabinet size WxDxH
S08	max. 650	max. 505	1120	380	330	230	490	13.5	255 ± 10	470 ± 30	800x600x2000
S10	890	max. 505	1120	370	514	n/a	280	13.5	255 ± 10	240 ± 30	1000x600x2000
S12	1060	max. 505	1120	370	684	n/a	28	13.5	255 ± 10	230 ± 10	1200x600x2000
L08	max. 680	max. 557	1320	458	320	225	485	13.5	290 ± 10	540 ± 30	800x600x2000
L10	890	max. 557	1320	455	504	n/a	258	13.5	290 ± 10	230 ± 10	1000x600x2000
L12	1060	max. 557	1320	455	674	n/a	285	13.5	290 ± 10	220 ± 10	1200x600x2000

Table 28 Dimensions of all frame sizes in inches

Frame size	W	D	H	R	S1	S2	S3	T	LINE	LOAD	Recommended cabinet size WxDxH
S08	max.25.6	max. 19.88	44.09	14.96	12.99	9.06	19.29	0.53	10.04 ± 0.039	18.5 ± 1.18	31.5x23.6x78.7
S10	35.04	max. 19.88	44.09	14.57	20.24	n/a	11.02	0.53	10.04 ± 0.039	9.45 ± 1.18	39.4x23.6x78.7
S12	41.73	max. 19.88	44.09	14.57	26.93	n/a	11.02	0.53	10.04 ± 0.039	9.06 ± 0.39	47.2x23.6x78.7
L08	max. 26.8	max. 21.93	51.97	18.06	12.60	8.86	19.09	0.53	11.42 ± 0.039	21.26 ± 1.18	31.5x23.6x78.7
L10	35.04	max. 21.93	51.97	17.91	19.84	n/a	11.22	0.53	11.42 ± 0.039	9.06 ± 0.39	39.4x23.6x78.7
L12	41.73	max. 21.93	51.97	17.91	26.54	n/a	11.22	0.53	11.42 ± 0.039	8.66 ± 0.39	47.2x23.6x78.8

3.13 Filter performance

Ecosine Max Passive Harmonic Filters achieve 5% THDi with 6-pulse diode rectifiers under the following condition.

- | Filter is applied to rated voltage and power
- | THDv <2%, line voltage unbalance <1%
- | 5% THDi is not guaranteed for thyristor rectifier application. The performance of the filter is dependent on the firing angle of the thyristors.

Ecosine Max filter performance (THDi, power factor and Udc) under different load conditions are shown in the following charts.

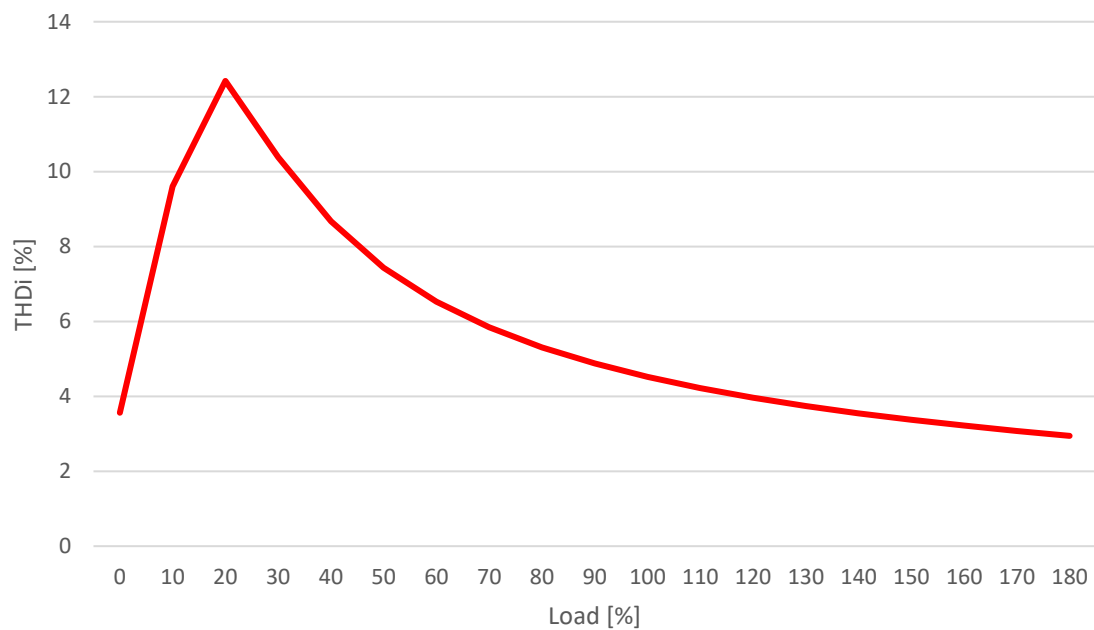

Figure 14 THDi vs. load (diode rectifier front-end)

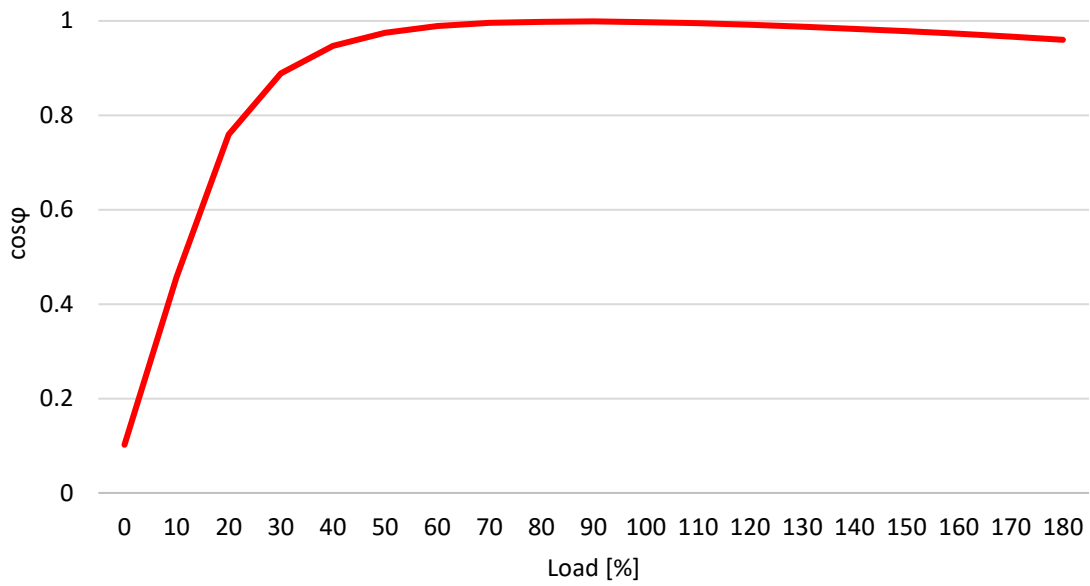

Figure 15 Power factor vs. load (diode rectifier front-end)

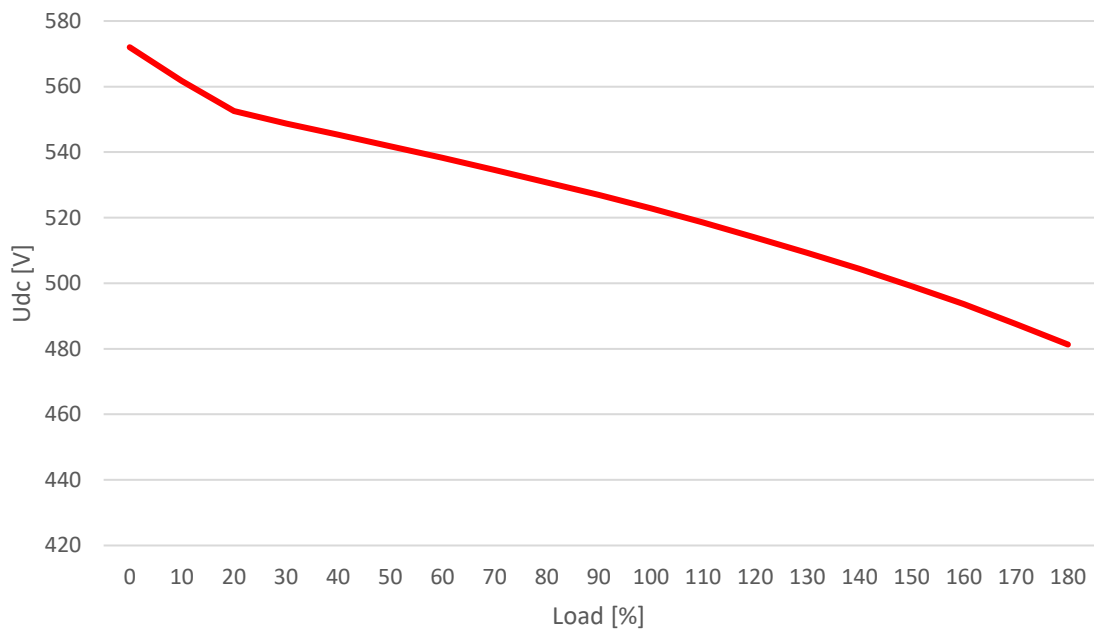
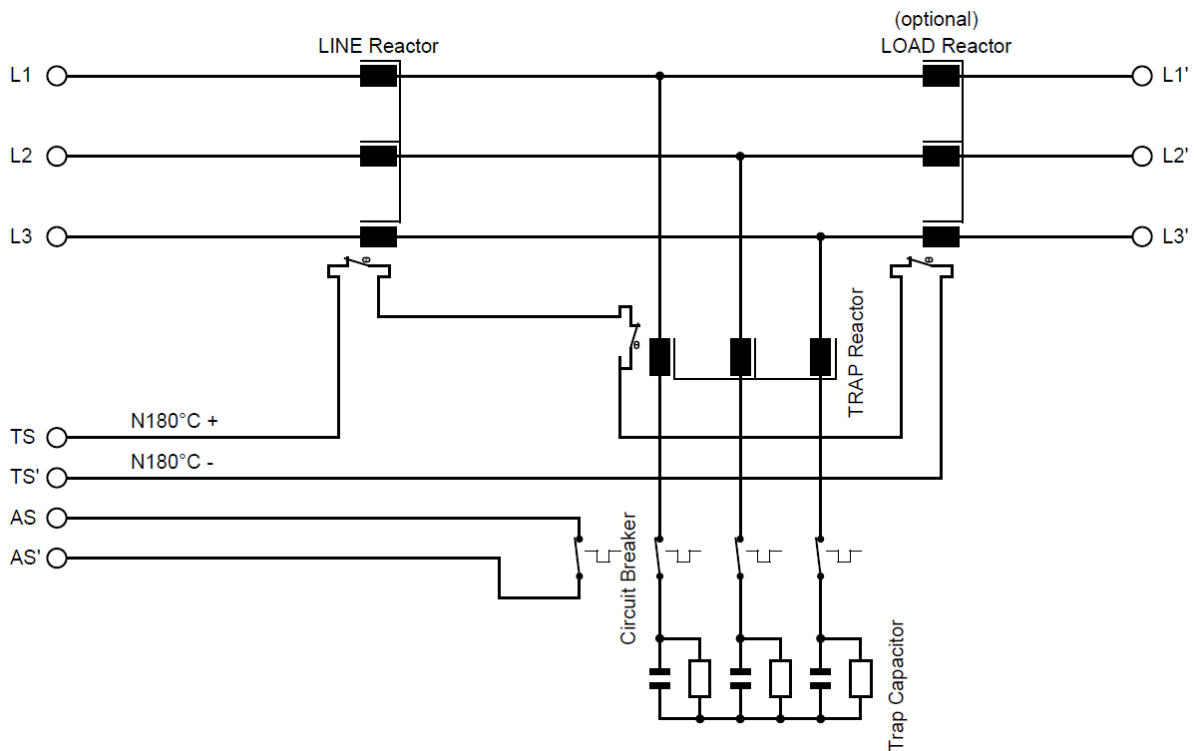

Figure 16 Drive dc-link voltage vs. load (diode rectifier front-end, with FN3471 series and drive with 4% Ldc)

3.14 Functional diagram

3.14.1 Filter configuration



Filter terminals	Line L1/L2/L3	3 busbar terminals at line side
	Load L1'/L2'/L3'	3 busbar terminals at load side
	TS, TS'	Connecting terminals to thermal switch NC 180°C (UL-approved) to detect overload in chokes
	AS, AS'	Terminal for auxiliary connection, details refer to section 8.3.8
	PE	Protective earth. Threaded stud with washer and nut
Function blocks	Chokes	Power magnetic components incl. temperature switches
	Capacitors	Power capacitors incl. discharge resistors
	Circuit breaker	Make sure the status is "On" when install the filter Status "On" during normal operation Investigation of the system is required when the status of the switch changed to "Off"

3.14.2 Filter configuration -E0XXJXX

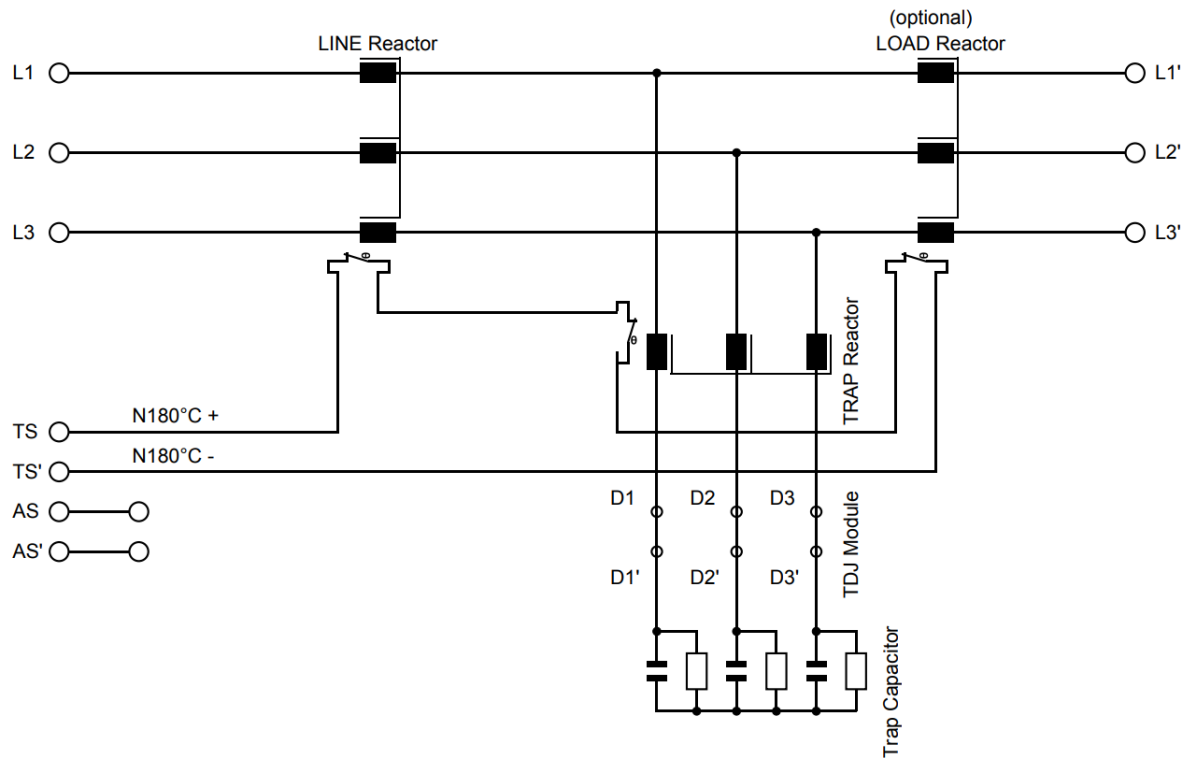

Filter terminals	Line L1/L2/L3	3 busbar terminals at line side
	Load L1'/L2'/L3'	3 busbar terminals at load side
	TS, TS'	Connecting terminals to thermal switch NC 180°C (UL-approved) to detect overload in chokes
	AS, AS'	Terminal for auxiliary connection, details refer to section 8.3.8.
	PE	Protective earth. Threaded stud with washer and nut
	Trap disconnect D1, D2, D3 D1', D2', D3'	3 couples of terminals. For optional configurations with TDJ, wire bridges are installed for immediate operation of the filter. They allow for the connection of <ul style="list-style-type: none"> an external circuit breaker an external circuit breaker in series with a capacitor contactor to disconnect the trap circuit at partial load (frequent use) an external circuit breaker together with a remote control module to disconnect the trap circuit at partial load (occasional use)
Function blocks	Chokes	Power magnetic components incl. temperature switches
	Capacitors	Power capacitors incl. discharge resistors
	Trap disconnect jumper	Terminals for installing circuit breaker or capacitor contactor by customers themselves

4 Ecosine Max filters schematics and working principle

The base module of FN3471, FN3473, FN3481 and FN3483 series contains line choke, trap choke and trap capacitor, which helps reduce THDi to 5% for motor drives with an 4% DC-link choke present.

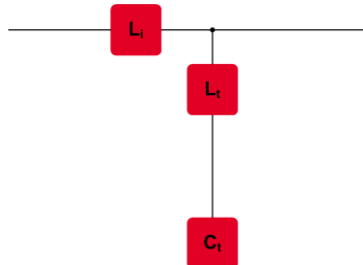

Figure 17 Schematic of FN3471, FN3473, FN3481 and FN3483 filter series

The base module of FN3470, FN3472, FN3480 and FN3482 series contains line choke, load choke, trap choke and trap capacitor, which helps reduce THDi to 5% for motor drives without DC-link choke present. The base module schematic is shown in Figure 18.

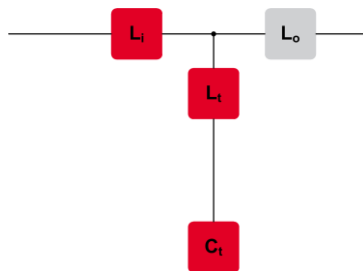

Figure 18 Schematic of FN3470, FN3472, FN3480 and FN3482 filter series

General working principle of Ecosine Max filter base modules is shown in Figure 19.

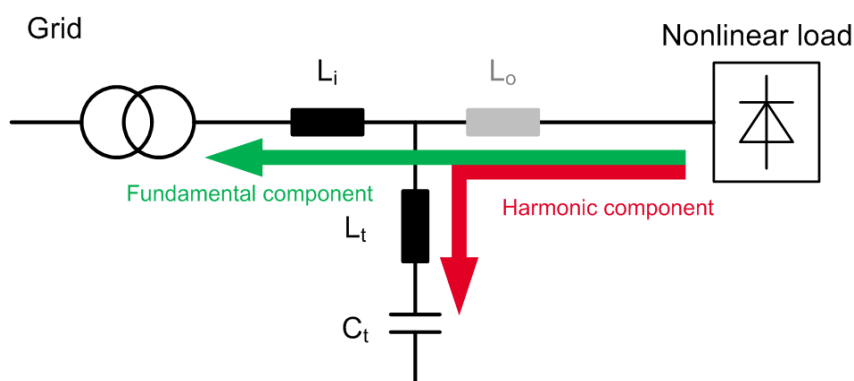

Figure 19 Working principle of Ecosine Max Passive Harmonic Filters (with load choke L_o and without)

There is either trap disconnect jumper module or trap disconnect switch module available for FN3470/FN3471, FN3472/FN3473, FN3480/FN3481 and FN3482/FN3483 filters.

5 Filter appearance and elements

Ecosine Max Passive Harmonic Filters are available in IP00 open frame, and all designed for floor-mounted installation. The compact design makes it an optimized open frame for cabinet integration. The filter is all-wired with 3 inputs and 3 outputs, which can be easily installed into standard and customized cabinet.

The appearance of the filters can be differentiated depending whether the load choke is present or not in the filter.

5.1 Mechanical design of FN3470/80/72/82 (with load choke present)

The general design of FN3470/80/72/82, filters with load choke and circuit breaker module (E0XXSXX) is shown in Figure 20.

On the right side of the frame, there is trap choke L_t sitting on top of the line choke L_i , and the load choke L_o is next to them. The trap capacitor C_t and circuit breaker or trap disconnect jumper is mounted on the left side of the frame.

Switch module, namely a circuit breaker, is required in high power passive harmonic filters for safety reasons. The short circuit current of high power passive harmonic filters can go beyond 10'000A, however the capacitors are only protected with failure current of max. 10'000A. Therefore, an external switch able to disconnect the capacitors automatically under overloading and short circuit conditions is mandatory to ensure the installation safety at all operation situations. When the filter is overloaded, depending on the overcurrent value, circuit breaker will release after a certain time. The faster and higher the current rise is, the faster will the circuit breaker release. The characteristics curve of current and tripping time and more information can be found in the circuit breaker datasheetⁱ. In case the circuit breaker is released, the connected load must be shut down immediately and remains off until the failure is investigated, and problem is solved. Once everything solved and source of issue removed, the circuit breaker can be switched on again to re-start the system.

ⁱ Online datasheet and documentation for circuit breaker [250A](#), [300A](#), [400A](#) and [500A](#)

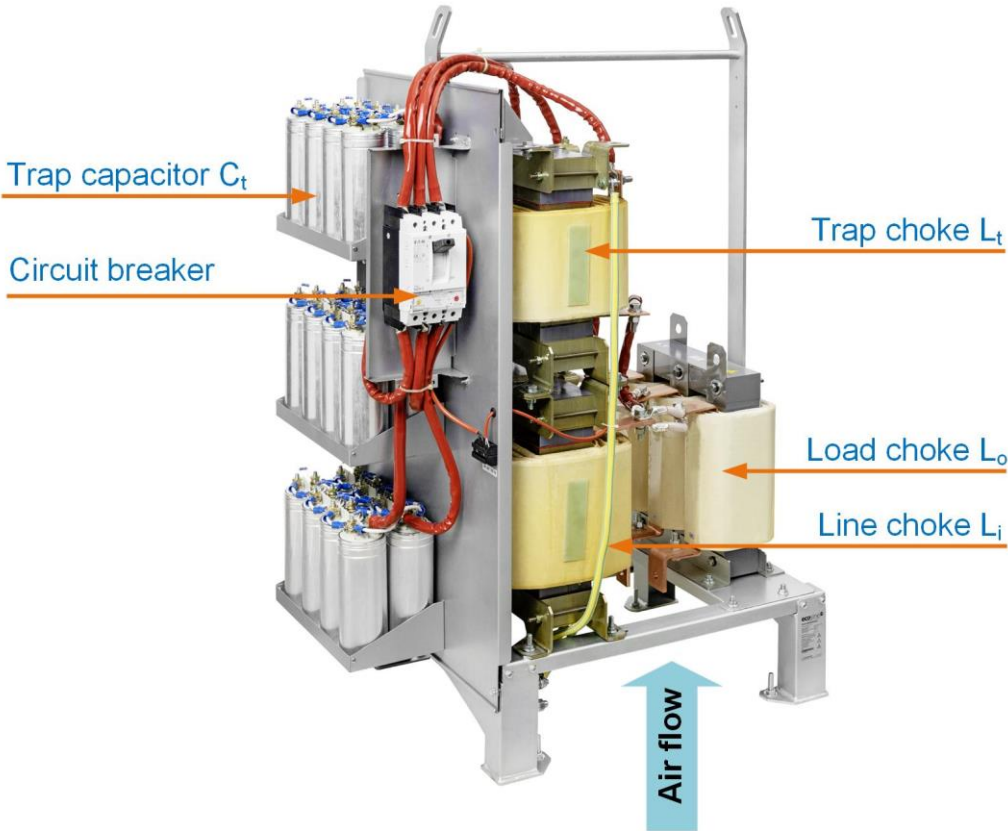

Figure 20 Design of FN3470/80/72/82 filter (Type E0XSXX)

5.2 Mechanical design of FN3471/81/73/83 (without load choke present)

The general design of FN3471/81/73/83, filters without load choke present, and with circuit breaker module (E0XXSXX) is shown in Figure 21.

On the right side of the frame, there is trap choke L_t sitting on top of the line choke L_i . The trap capacitor C_t , and circuit breaker or trap disconnect jumper is mounted on the left side of the frame.

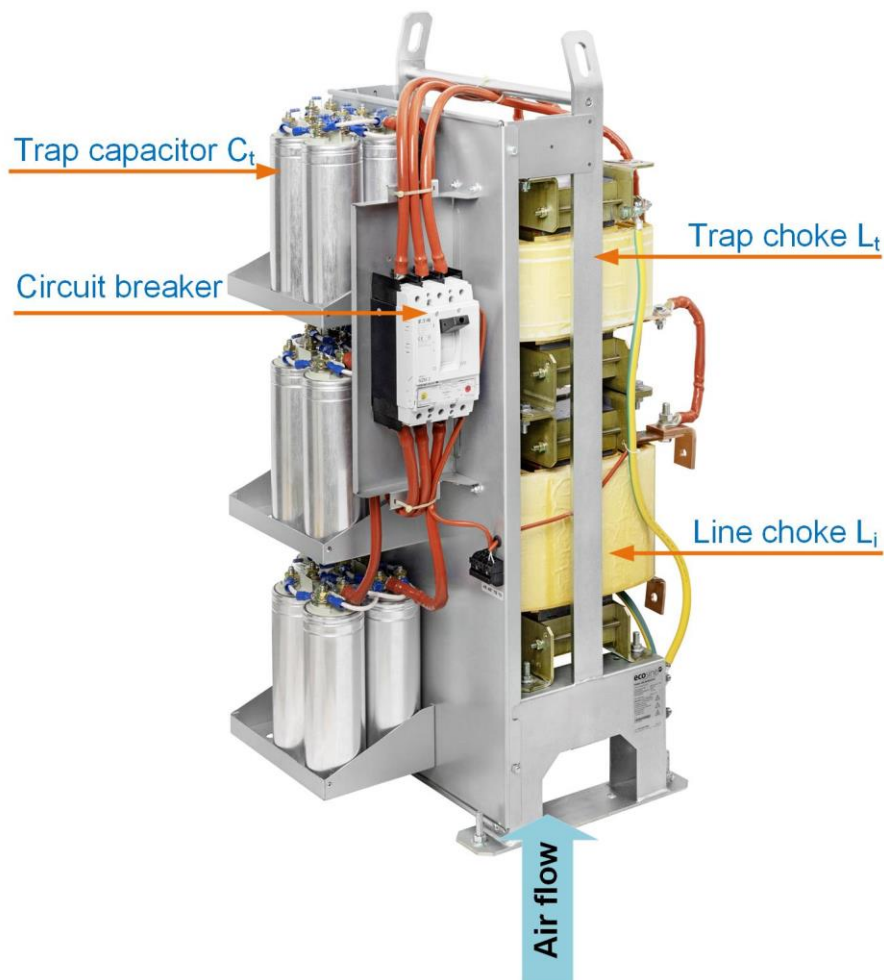

Figure 21 Design of FN3471/81/73/83 filter (Type E0XXSXX)

5.3 Mechanical design of filters with trap disconnect jumper terminal option

The general design of FN3470/80/72/82, filters with load choke present, and with trap disconnect jumper terminals (E0XXJXX) is shown in Figure 22, while design of FN3471/81/73/83 without load choke present, and with trap disconnect jumper terminals (E0XXJXX) is shown in Figure 23.

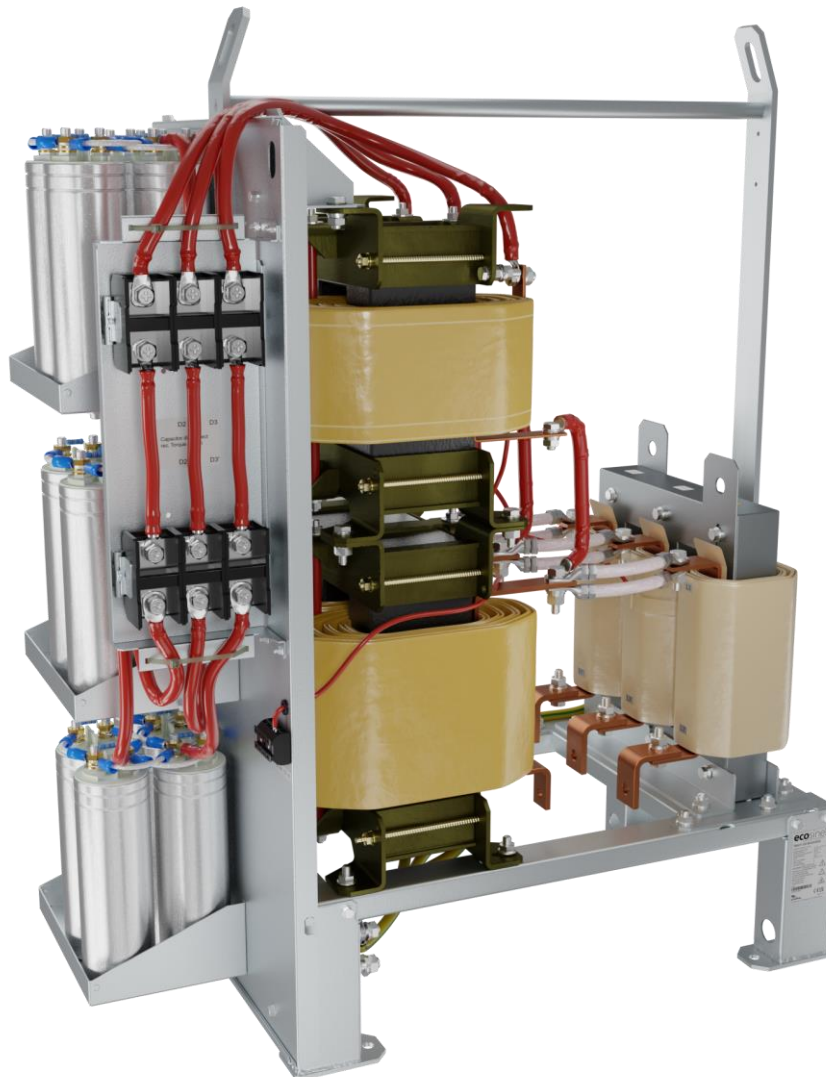

Figure 22 Design of FN3470/80/72/82 filter (Type E0XXJXX)

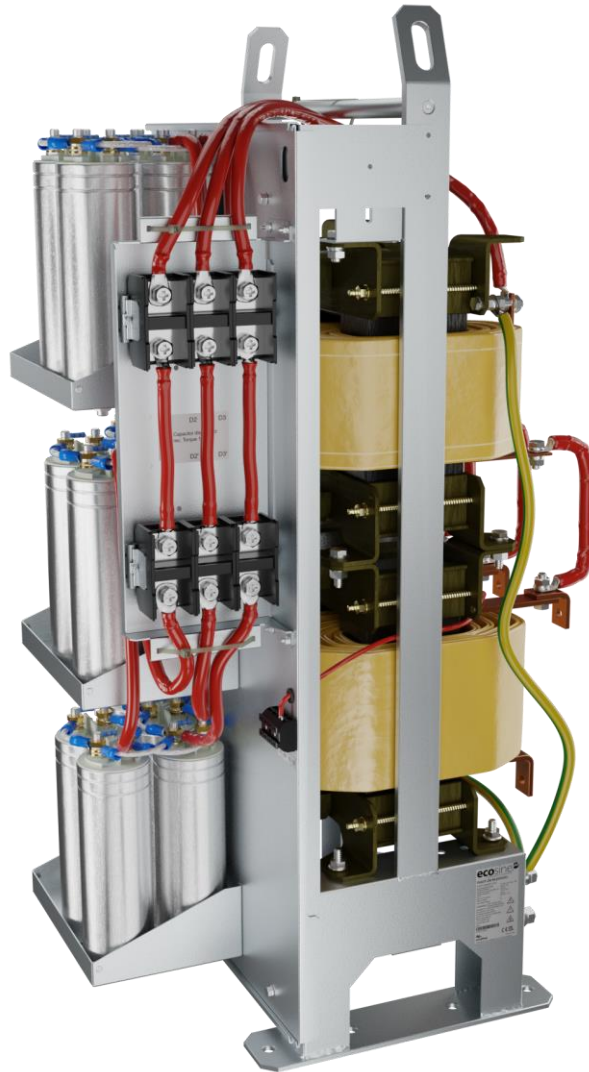
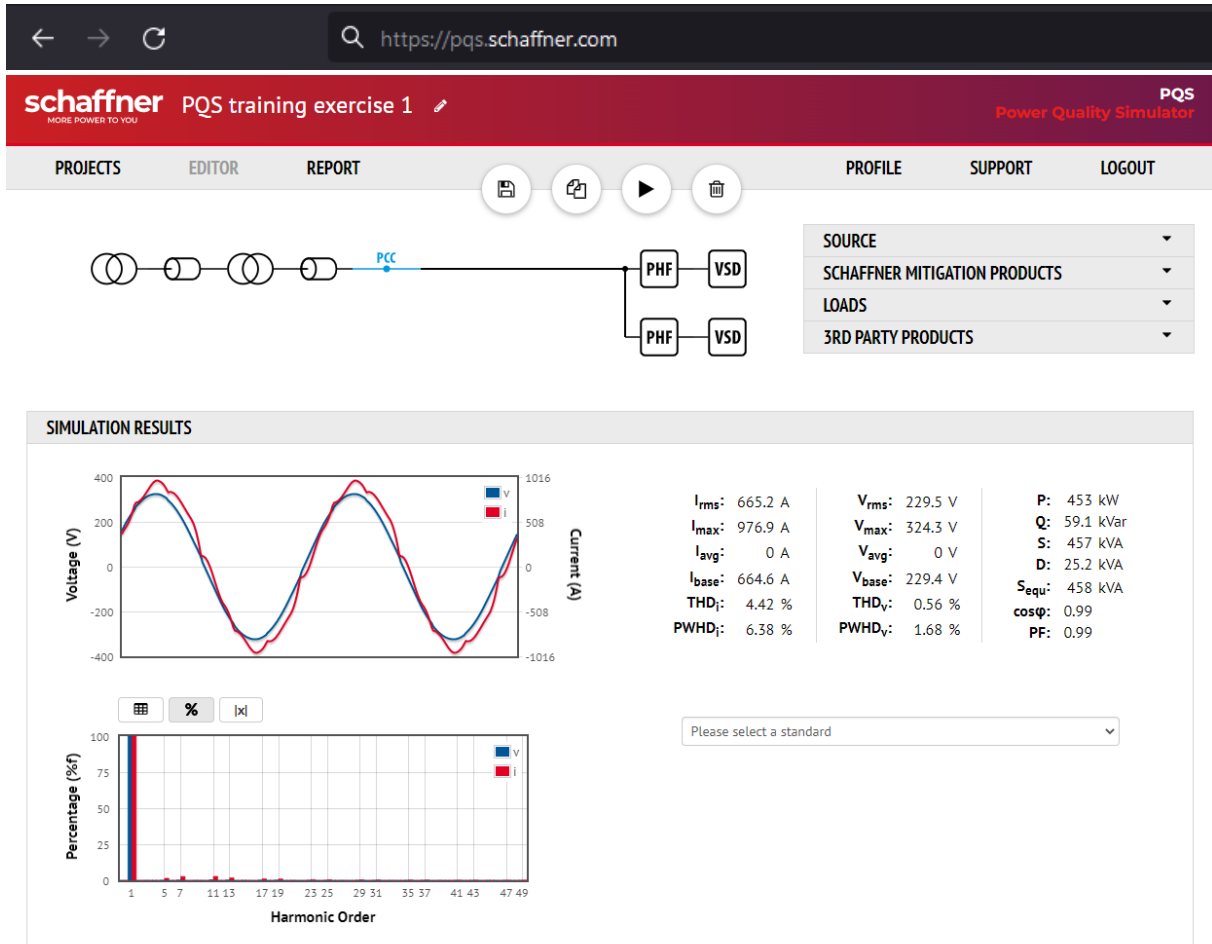

Figure 23 Design of FN3471/81/73/83 filter (Type E0XXJXX)

6 Performance estimation using SchaffnerPQS

Ecosine Max Passive Harmonic Filters are included and can be simulated with the Schaffner Power Quality Simulator SchaffnerPQS pqs.schaffner.com.

By using SchaffnerPQS, users can easily simulate and estimate system performance taking into account the most important design requirements and system's boundary conditions.



7 Filter application

Ecosine Max Passive Harmonic Filters are designed to mitigate harmonic current of non-linear loads, particularly of three-phase diode-type rectifiers. Contrary to “bus-applied or PCC (Point of Common Coupling)” filters, which are being installed e.g. at the main feeder, ecosine passive harmonic filters are specifically designed to be used with either an individual non-linear load, or with a group of non-linear loads.

One advantage of load-applied filtering is the fact that the upstream power (relative to the harmonic filter) is clean, i.e. unloaded by the harmonics. This can be of vital importance when the same power bus supplies both motor drives and sensitive loads. Ecosine Max Passive Harmonic Filters are also suitable for paralleling lower power non-linear loads on a higher power harmonic filter to improve overall system economy. In this case the total expected load power of all connected drives must match the filter.

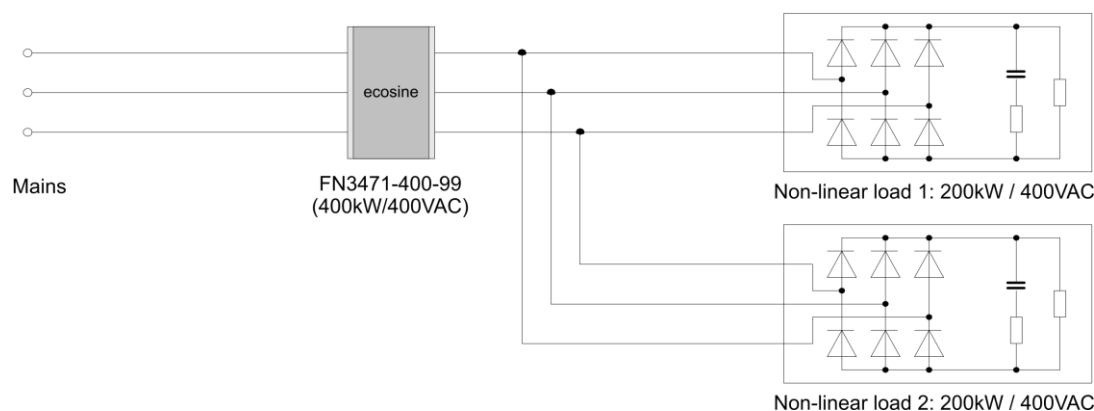

Figure 24 Application example with multiple loads per filter

If the expected input power exceeds the rating of the largest available filter, and a custom solution is not desired, then two filters can be wired in parallel. In this mode of operation, it is mandatory to use filters with equal power ratings to ensure proper current sharing.



Warning: in case of parallel use of Ecosine Max filter, customer must ensure that both filters have an appropriate over current protection on the trap capacitor (same for both filter), either using the optional switch -E0XXSXX or by installing a third party switch circuit breaker using the trap disconnect jumper option -E0XXJXX.

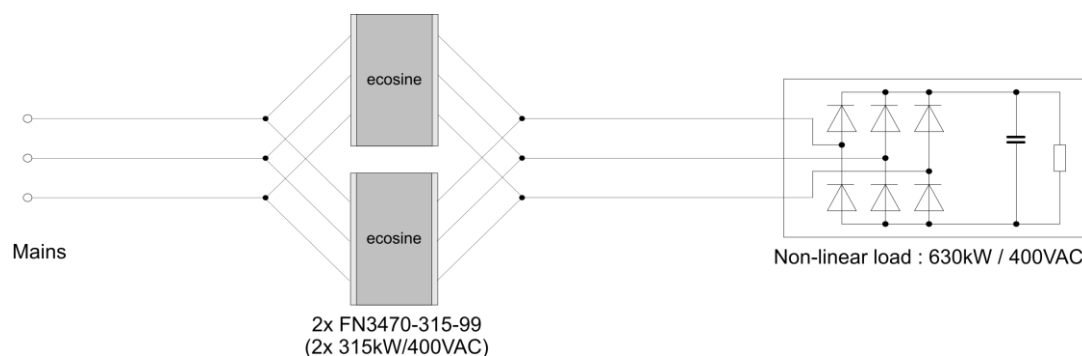

Figure 25 Application example with 2 filters in parallel for larger load

8 Filter installation

Please follow the simple steps below to ensure a safe and reliable filter function for many years. Please do always follow the general safety and installation guidelines provided within this document as well as relevant local, national or international standards that are applicable. Please note that the following installation steps are applicable for all Ecosine Max filters; FN3470, FN3471, FN3472, FN3473, FN3480, FN3481, FN3482 and FN3483.

8.1 Step 1: Visual inspection

All Schaffner Ecosine Max Passive Harmonic Filters have undergone rigorous testing before they left our ISO 9001:2015 certified factories. They are packaged with great care in a sturdy container for international shipment.

However, carefully inspect the shipping container for damage that may have occurred in transit. There are two TiltWatches and one ShockWatch attached on the packaging, in case one or more of the TiltWatch and ShockWatch indicating a record of unacceptable tilting or shock on goods (indicator turned red partially or totally), please file a claim with the forwarder immediately before unpacking anything. If both TiltWatches and the ShockWatch are good, unpack the filter and carefully inspect for any signs of damage. Keep the shipping container for future transportation or storage of the filter.



Figure 26 Location of TiltWatches and ShockWatch

In the case of damage, please file a claim with the freight forwarder involved immediately and contact Schaffner or our local partner for support. Under no circumstances install and energize a filter with suspected transportation damage, whether it is clearly visible or not.

If the filter is not going to be put in service upon receipt, store within the original container in a clean, dry location, free of dust and chemicals and with respect to named temperature limits, see section 2.

8.2 Step 2: Mounting

Ecosine Max Passive Harmonic Filters are best installed as close as possible to the non-linear load. Ideally, they are mounted next to the rectifier or motor drive inside the electrical cabinet or control room. All Ecosine Max Passive Harmonic Filters are designed for floor mounting installation inside a cabinet. Inside the cabinet the filter must be placed as much as possible on the left side with a clearance of about 10mm to the inner frame of the cabinet. Additionally, the customer must ensure that the filter can be taken out straight from the front door of the cabinet, depending on the cabinet reference the exact position might be adjusted accordingly.

Note:

The filter placement on the left (capacitor side) is meant to improve air cooling of the capacitor and to allow as much as possible free space on the terminal side for power cables or busbar connections.

Important:

To ensure sufficient air flow, keep a clearance of min.150mm above the filter to ceiling or other components inside the cabinet. The outside distance between the cabinets is not restricted as far as accessibility is guarantee (front door can fully open). Please also ensure to comply with cooling requirement described in section 3.8.

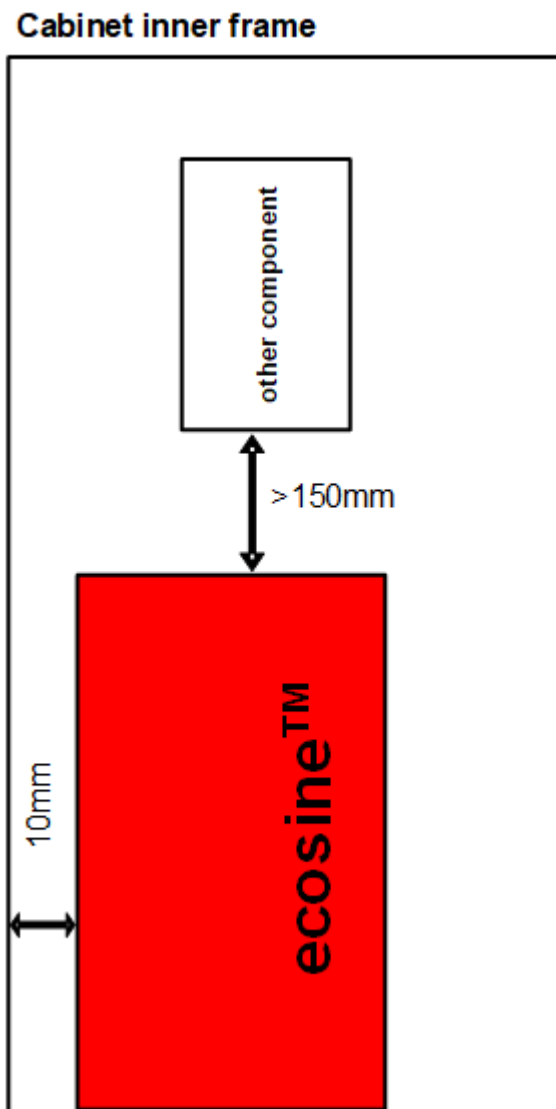

Figure 27 Clearance inside cabinet

8.2.1 Fixation

Screw hole positions for mounting the filters as indicated in Table 29:

Table 29 Dimensions of frame sizes

Frame size	Drill pattern [mm]		
	R	S1	S2
S08	380	330	230
S10	370	514	n/a
S12	370	684	n/a
L08	458	320	225
L10	455	504	n/a
L12	455	674	n/a

T = 13.5 mm for all frame sizes

All dimensions in mm; 1 inch = 25.4mm

Filters FN3471/73/81/83 in frame size S08 and L08 offer two possibilities of fixation points.

The preferred fixation points have a distance S1 between the screws on the terminal side and screws on the capacitor side as shown in Figure 29.

Other permitted fixation points are offered in case of difficult accessibility of the rear fixation points. Those permitted fixation points have a distance S2 between the screws on the terminal side and screws on the capacitor side as shown in Figure 30.



Warning: In all cases, the usage of the two fixation screws on terminal side (right side on Figure 28, Figure 29 and Figure 30) is mandatory. The usage of shorter distance than S2 between fixation points and usage of less than 4 fixation screws is forbidden and could result in damage to the product and serious injuries.

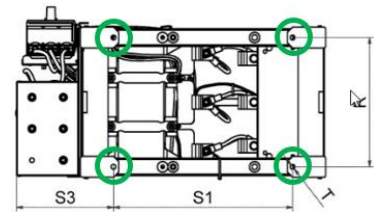

Figure 28 Fixation points for filters FN3470, FN3472, FN3480 and FN3482

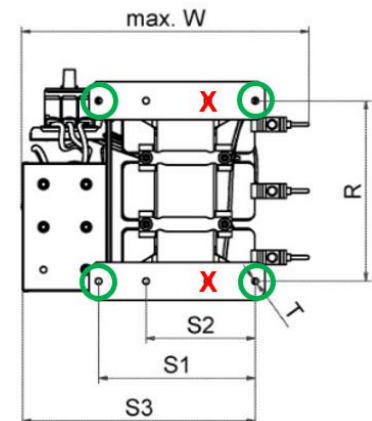

Figure 29 Preferred (green) and forbidden (red) fixation points for filters FN3471, FN3473, FN3481 and FN3483

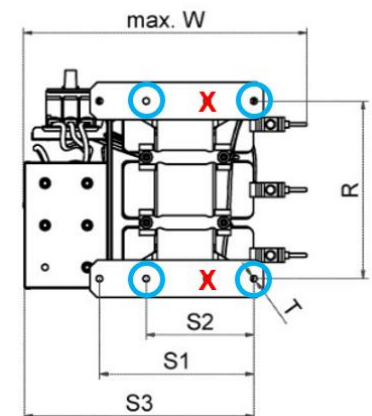

Figure 30 Permitted (blue) and forbidden (red) fixation points for filters FN3471, FN3473, FN3481 and FN3483

8.2.2 Screws and bolts selection

Depending on the cabinet specification, the heavy load fixation system might be providing either screws/rods or nuts adapted to the specific system. For the other part of the bolts (respectively the nut or screw) Schaffner recommends zinc coated hex ribbed flange steel screws or nuts. Respect filters weight for appropriate choice of screws! Head diameters must not exceed these dimensions:

M12: $d \leq 24$ mm

Refer to the cabinet supplier documentation for more information.

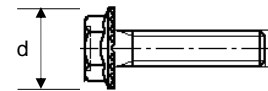

8.2.3 Filter placement

1. Lift filter with appropriate crane using the two lifting slots (dimensions of the slot 20x50mm).
2. Place the filter as precisely as possible by aligning the fixation holes on the filter with the matching nuts holes or rods on the base frame.
3. Insert the 4 screws or nuts and screw them approximately 1mm before the head touch the surface.
4. Double check the proper alignment and parallel position.
5. Fix screws with appropriate torque (depending upon the material of the cabinet fixation system and local standards).



Warning: the equipment weight is ≥ 240 kg

Handling and lifting of heavy equipment must always comply with your local safety standard.



Figure 31 Location of lifting slots



Danger: respect lifting angle, risk of severe damage

The maximum allowed angle between the lifting rope and vertical plan should not exceed 45°. Failing to comply might destroy the equipment and induce a risk of severe injuries.

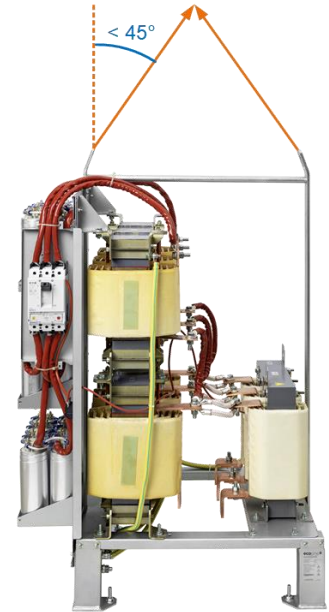

Figure 32 Maximum angle of lifting force

8.3 Step 3: Wiring

8.3.1 Verify safe disconnection of all line side power

Consult your local safety instructions.



8.3.2 Carefully connect protective earth (PE) cable to adequate earth potential close to ecosine filter

Use a cable with diameter of equal or bigger size as foreseen for line/load side power cables – according to your local codes and safety instructions.

8.3.3 Connect PE cable of Ecosine filter

with appropriate cable lug to threaded stud.

torque M12: 20-25 Nm



8.3.4 Connect Ecosine main terminals to the respective phase on the line and load/rectifier

The main cables must have an appropriate M12 cable lug. In case of busbar connections, the contact surface and hole size must be appropriate to the filter busbar terminals and fitting M12 screws and bolts. Cables must be routed from below the cabinet and vertically below each busbar terminal.



Warning: during installation of cables, clearance and creepage distance must not be shortened. Live part of cable like the cable lug must not be in contact with any other part (live part, earthed part or insulated part), additionally insulation of the cable should not touch directly any live part. This can be ensured by keeping the cable in vertical position below each terminal during installation of cables.

Connect the cables to the busbar as follow:

1. Connect line phase L1 to the terminal L1
2. Connect load/rectifier phase L1' to the terminal L1'
3. Connect line phase L2 to the terminal L2
4. Connect load/rectifier phase L2' to the terminal L2'
5. Connect line phase L3 to the terminal L3
6. Connect load/rectifier phase L3' to the terminal L3'

The appropriate torque for M12 is 20-25Nm.

Please follow section 3.6 for appropriate cable or busbar selection.

Note: Depending on the possible short circuit current the main connection wires need to be fixed very strength near to the line and load terminals.

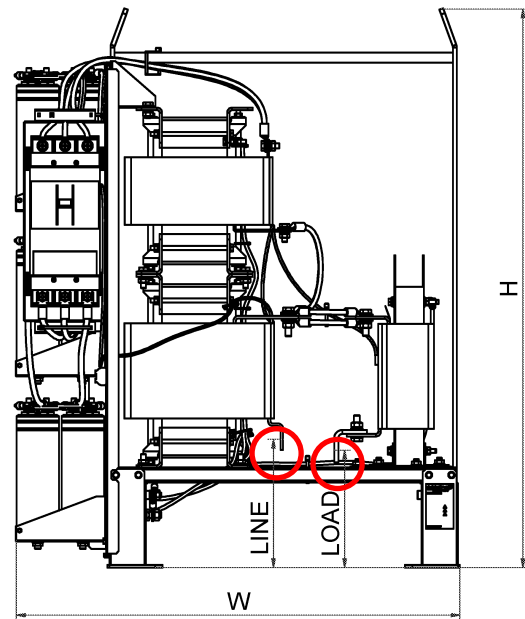

Figure 33 Location of line and load terminals for filters FN3470, FN3472, FN3480 and FN3482

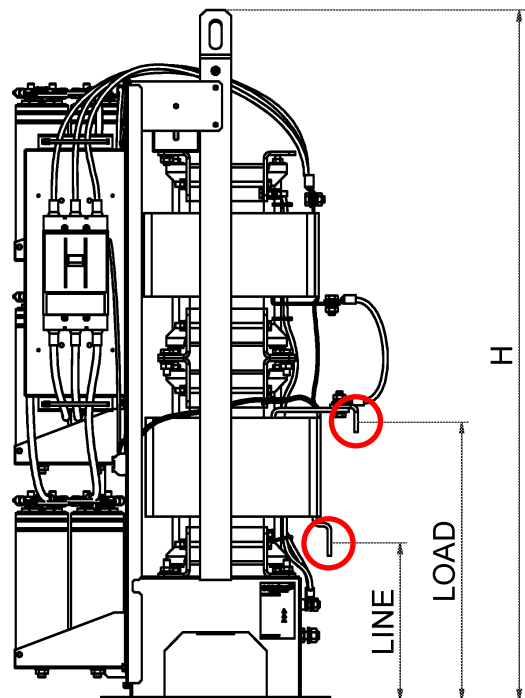

Figure 34 Location of line and load terminals for filters FN3471, FN3473, FN3481 and FN3483

8.3.5 Install an external switch circuit breaker (J versions only)

When selecting J versions of Ecosine Max, it is possible to install a third-party switch circuit breaker between the trap disconnect jumper terminals to protect the capacitors from overcurrent. The size and characteristics of the switch must be equivalent to the one provided with the S versions of Ecosine Max.

The rated current of the switch is given in the sections 2.1 to 2.4 in the tables for the S versions.

For reference, please check the circuit breaker manualⁱ for the switch used in S versions of Ecosine Max.



Warning: protection of the trap capacitor against overcurrent is required. It is forbidden to use the filter without any switch installed. The customer is fully responsible for any inappropriate usage of the filter.

8.3.6 Install external capacitive current control

For configurations with TDJ option, thus without integrated switch (see sections 2.1 to 2.4), terminals D1- D1', D2- D2' and D3- D3' are delivered with installed jumpers. This configuration allows to install any third-party switch circuit breaker (not supplied by Schaffner, see 8.3.5) and when necessary an additional capacitor contactor (not supplied by Schaffner).

The usage of a capacitor contactor in line in the trap capacitor circuit allows for load dependent disconnection of the trap circuit, if needed. Therefore, capacitive current can be minimized for low load operation.

Estimation of required capacitor contactor size: see box to the right.



Warning: protection of the trap capacitor against overcurrent is still required even when using a contactor because it will not react to overcurrent. It is forbidden to use the filter without any switch installed. The customer is fully responsible for any inappropriate usage of the filter.

Contactor performance estimate:

Example: FN3470-**500**-99-E0XXJXX

The nominal power rating in kW multiples by 50% and the ratio between the grid voltage and the nominal voltage (400 V for FN347X, 480 V for FN348X) is the approximate reactive power.

Contactor rating =

$$500kW * 50% * \frac{V_{grid}}{V_{nom}} =$$

$$500kW * 50% * \frac{400V}{400V} = 250kVAR$$

ⁱ Online datasheet and documentation for circuit breaker [250A](#), [300A](#), [400A](#) and [500A](#)

8.3.7 Connect monitor switch TS- TS'

The monitor switch is a relay contact, which is open in ALARM state. It is constituted by a thermal switch NC 180°C (UL-approved) to detect overload of chokes. It may either be used to remotely disconnect the drive's load via respective input of drive control (check drive manual) or as an alarm switch for system control unit.

For wire cross section recommendation see section 3.6.2.



Warning: an engaged monitor switch must lead to immediate load shutdown and investigation of the problem.

8.3.8 Connect auxiliary switch AS- AS'

For filter configuration with S option (pre-equipped with switch, see sections 2.1 to 2.4)

The auxiliary switch is a contact, which indicates the state of circuit breaker. It is closed under normal operation (CB on) and is open in abnormal condition (CB off). Abnormal condition can be a short circuit in the trap capacitors, overcurrent in the trap circuit, too hot ambient temperature or switch-off status in low load condition (use of motor mechanism together with the circuit breaker – check relevant section in the circuit breaker manualⁱ).

For filter configuration with J option (equipped with trap disconnect jumper for third party switch installation, , see sections 2.1 to 2.4)

The AS terminal block is installed, but not connected to any switch (empty terminal). Customer must connect the auxiliary switch of the additionally installed third party switch circuit breaker (NC, NO or other). The customer is fully responsible for the third-party switch installation, wiring and usage according to the respective manual.

For wire cross section recommendation see section 3.6.2.



Warning: an engaged auxiliary switch not resulting from a manual or remote-controlled opening must lead to immediate load shutdown and investigation of the problem.



Figure 35 terminal for auxiliary contact connection

ⁱ Online datasheet and documentation for circuit breaker [250A](#), [300A](#), [400A](#) and [500A](#)

8.3.9 Install and connect the switch remote operator

(Only relevant for filter with switch option, see sections 2.1 to 2.4 and with addition of remote operator module)

The remote operator for the switch allows to control remotely the switch on order when required for the application.

The remote operator module is not provided by Schaffner and when required, it needs to be bought separately. Please consult the relevant user manualⁱ for complete installation and usage.



Figure 36 Eaton switch remote operator module



Warning: the switch is a protection device; its purpose is to disconnect the trap capacitor circuit in case of overcurrent or over-heating. Usage of the switch with or without remote operator is never intended for frequent manual or on order opening (e.g. NzM 3 series allows only 2000 on load openings in its lifetime, please consult the switch manualⁱ for more information). For frequent commutation, the addition of a capacitor contactor in series with the switch circuit breaker is strongly recommended. Please refer to section 8.3.5, 8.3.6 and 10 for more details.

ⁱ Online datasheet and documentation for [remote operator](#)

8.3.10 Fuses

Ecosine Max Passive Harmonic Filters need external over-current protection for compliance with UL/cUL standard. Fuses and associated fuse holders must be UL listed and rated for 100kA SCCR supplies. Table 30 and Table 31 show requested fuse current ratings for UL class J/L and, where UL compliance is not mandatory, for IEC class gG. The fuse rating is independent of the supply voltage.

A system with multiple Ecosine Max filters paralleled for a higher power load need each a separate 3-phase line side fuse block, corresponding to the respective filter and according to Table 30 and Table 31.

The drive's application manual may prescribe line-side fuse protection as well, which in this case either corresponds to the sum of the filter fuse ratings or, if lower, would request separate drive fuses at its input.

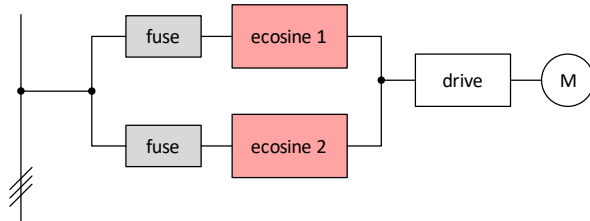

An application, having one ecosine filtering harmonics for several drives, requires in any case line side fuse protection of the drives as well as the correct filter protection according to Table 30 and Table 31 and section 8.3.6.

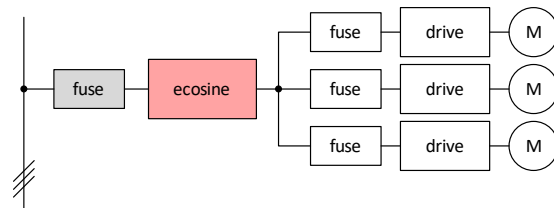

Table 30 Requested fuse current rating for UL class J/L and for IEC class gG

Ecosine	ecosine	ecosine	ecosine	Fuse class J/L	Fuse class gG
All FN3470	All FN3471	All FN3480	All FN3481	Rated current A	Rated current A
FN3470-250-99	FN3471-250-99	FN3480-315-99	FN3481-315-99	600 ⁱ	630
FN3470-315-99	FN3471-315-99	FN3480-355-99	FN3481-355-99	800 ⁱⁱ	800
FN3470-355-99	FN3471-355-99	FN3480-400-99	FN3481-400-99	800 ⁱⁱ	800
FN3470-400-99	FN3471-400-99	FN3480-500-99	FN3481-500-99	800 ⁱⁱ	800
FN3470-500-99	FN3471-500-99	FN3480-550-99	FN3481-550-99	1000 ⁱⁱ	1000

ⁱ UL class J

ⁱⁱ UL class L

Table 31 Requested fuse current rating for UL class J/L

Ecosine	ecosine	ecosine	ecosine	Fuse class J/L
All FN3482	All FN3483	All FN3472	All FN3473	Rated current A
FN3482-350-99	FN3483-350-99	FN3472-280-99	FN3473-280-99	400 ⁱ
FN3482-400-99	FN3483-400-99	FN3472-315-99	FN3473-315-99	600 ⁱ
FN3482-450-99	FN3483-450-99	FN3472-356-99	FN3473-356-99	600 ⁱ
FN3482-500-99	FN3483-500-99	FN3472-400-99	FN3473-400-99	800 ⁱⁱ
FN3482-600-99	FN3483-600-99	FN3472-480-99	FN3473-480-99	800 ⁱⁱ

ⁱ UL class J

ⁱⁱ UL class L

9 Filter maintenance

Ecosine Max Passive Harmonic Filters described in this manual are equipped with long life components that ensure a satisfactory function for many years under normal operating conditions. Any operation under extreme conditions such as over-temperatures, overvoltage situations, polluted environments etc. reduces the life expectancy. The following maintenance recommendations will help maximizing filter lifetime.

Warnings:



High voltage potential is involved in the operation of this product. Always remove line side power before attempting to perform maintenance and let ample time elapse for the capacitors to discharge to safe levels (<42 V). Residual voltages are to be measured both line to line and line to earth.



Line side power must be disconnected prior to replacement of any part.

9.1 Maintenance schedule

Table 32 Maintenance schedule

year	1	2	3	4	5	6	7	8	9	10	11	12
check & tighten el. Connections ⁱ	X	X	X	X	X	X	X	X	X	X	X	X
check el. values of capacitors		X		X		X		X		X		X
replace power capacitors										X		

ⁱ Only external connections need to be checked.

9.2 Power capacitors

The power capacitors supplied with the filter modules are high quality components with an expected lifetime of up to 100'000 hours (11 years). Nevertheless, their useful service life can be shortened by electrical or thermal stress beyond their specification.

Power capacitor damage may also be caused by severe abnormal supply voltage peaks (i.e. lightning – depending upon system protection) but may only be recognizable through the measurement of line side harmonics distortion. This may be checked with a modern energy meter or by regular checkup with a power quality analyzer. According to the above considerations, a 2-year inspection interval is advisable.

Note: an inspection should also be performed after extreme overvoltage situations in the system.

9.2.1 Storage of capacitors

Up to 3 years-long storage, electrolytic capacitors can be operated without any restriction and the nominal voltage can be applied without any preliminary preparation. System reliability and life-time expectancy are not affected.

On the other side, a longer (>3 years) storage of electrolytic capacitors without applying any voltage can weaken the dielectric properties because of dissolution processes. The electrolytic solution is aggressive, it can affect and weaken the dielectric in the timeframe between production and product commissioning. The weak points are responsible for the higher leakage current shortly after the device turn-on on site.

The residual current of electrolytic capacitors depends upon time, voltage and temperature. The residual current increases after long storage without applying voltage.

The amplitude of resulting residual current during unit commissioning can be up to 10 times larger in the short term. The capacitor's residual current assumes the typical expected value at steady state for nominal voltage.

During commissioning after long storage, it is recommended to restore the dielectric characteristics by applying voltage progressively and with respect to the time frame the filters have been stored.

9.3 Electrical connections

Depending upon the environment and application, electrical connections, especially threaded bolts and nuts, can degrade over time by means of losing their initial tightening torque. This holds true not only for the filter, but for any such joint within an electrical installation.

Therefore, Schaffner recommends checking and tightening all electrical connections when a regular scheduled maintenance of the entire device that incorporates the filter is ongoing. Checking of internal connections within the filters is not needed or should be conducted by a Schaffner service representative.

10 Trap circuit disconnect

The trap disconnect jumper is an option allowing to connect a third-party switch and, when required, to add a capacitor contactor in series for the purpose of reducing the capacitive current during low load operation. With permanently connected trap circuit, $\cos\phi$ vs. load shows following characteristics:

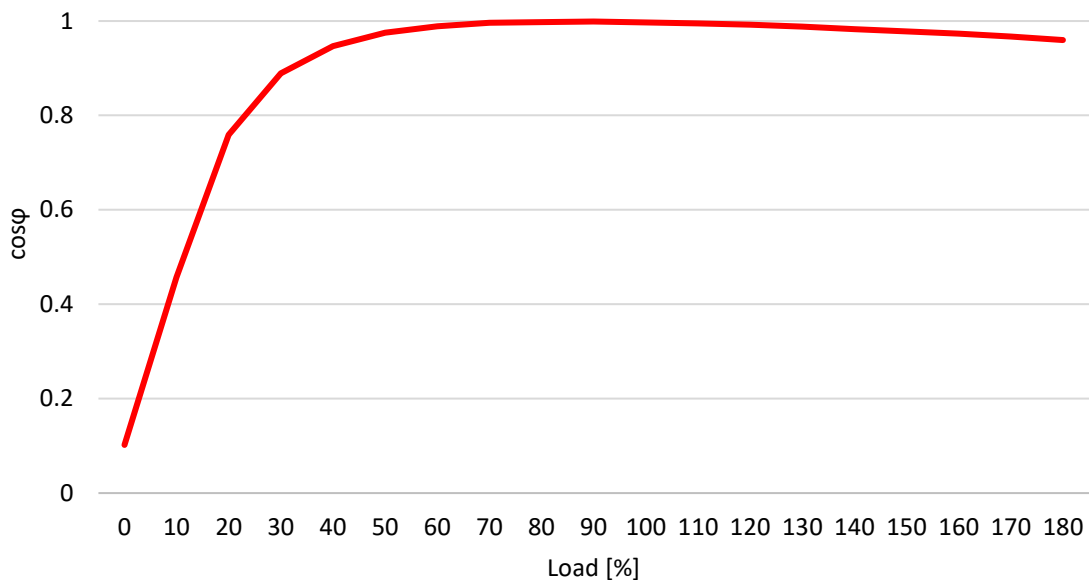

Figure 37 Power factor vs. load (diode rectifier front-end) (see section 3.13)

When the trap circuit is disconnected, $\cos(\phi)$ returns to ~ 0.98 . At the same time, the THDi will increase. This may be negligible since absolute values are low due to reduced load power. Needed external components (not part of ecosine filter) or system functions for fully automated capacitive current control:

- Motor load (power factor) monitoring device
- Capacitor contactor

A reduced load system status may be available as system controller output signal. In this case, only adequate driving of capacitor contactor must be assured.

Note: It is necessary to consider the overall concept of power factor correction. A power factor correction (PFC) system with large capacitor banks may become obsolete or massively reduced, when harmonic filters are installed. In such cases it may not be necessary to install trap circuit disconnect functions.

11 Troubleshooting

Schaffner ecosine harmonic filters are high quality products and have undergone rigorous testing and qualification procedures. Every unit runs through suitable tests in our ISO 9001:2015 factories. Due to this reason no major issues need to be expected if the filter is installed, operated, and maintained as described in this document.

In the unlikely event of a problem, please contact Schaffner or your local partner for assistance.

12 Abbreviation

Ecosine Max:	Refer to the product series Ecosine Max Passive Harmonic Filters
PHF:	Passive Harmonic Filter
PWM:	Pulse Width Modulation
f_{PWM} :	Frequency of the PWM or switching frequency
TDJ:	Trap Disconnect Jumper module

To find your local partner within
Schaffner's global network, please visit
schaffner.com

The information contained within this document and the functions offered are solely intended to provide information about products available for purchase from Schaffner group companies ("Schaffner") and do not constitute an offer for purchase or sale or a recommendation or advice. The content of this document has been carefully prepared and reviewed and all reasonable efforts have been made to ensure the accuracy of the information. However, Schaffner does not warrant the accuracy and does not assume any liability whatsoever for any errors or inaccuracies of this document and the consequences thereof. Schaffner accepts no responsibility or liability for any losses or damages of any kind arising out of the use of this document or any of its related functions. Further, Schaffner cannot be held responsible for any errors or unexpected unfulfillment of shipments. Schaffner reserves the right to make changes to this document, the products, the published specifications and any other functions at any time without notice. Product suitability for any area of application must ultimately be determined by the customer. In all cases, products must never be operated outside their published specifications. Schaffner does not warrant, represent or guarantee the availability of any or all published products. The latest publications and product specification sheets as well as the current Schaffner general terms and conditions and data protection policy apply; these documents and the complete legal disclaimer can be downloaded from the Schaffner website. In order to improve readability, the masculine form is mainly used for people and personal nouns in this document. All references to persons apply equally to all genders. The abbreviated language form has only editorial reasons and does not imply any valuation.

All intellectual property rights, such as trademarks, tradenames, designs and copyrights, are reserved and are exclusively owned by Schaffner Holding AG. This document may exist also in other languages. This version is valid and binding.

This disclaimer shall be governed by substantive Swiss law and resulting disputes shall be settled by the courts at the place of business of Schaffner Holding AG.

© 2023 Schaffner Holding AG

