

# Pulse Transformer with Single Secondary Winding

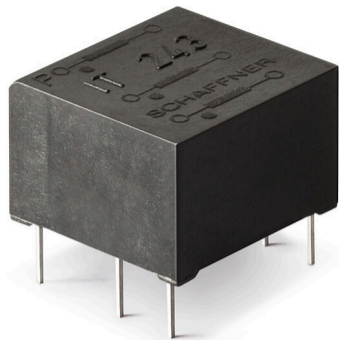

- Galvanic separation of drive and power circuit
- Voltage resistance up to 8 kV
- Ignition current up to 3 A
- Turns ratio up to 3:1



## Approvals & Compliances



IT pulse transformers are designed to offer you galvanic isolation for transformer coupled gate drives. The IT series provides negligible delays and the possibility of voltage scaling. They are available with single or double secondary winding for multiple gate drives. Choosing the IT product line brings you the rapid availability of a standard gate drive transformer. A wide selection on turns ratio, ignition current and voltages are designed to offer you the desired standard product.

## Features and Benefits

- Galvanic separation
- Voltage resistance up to 8 kV
- Allows high potential difference voltage scaling
- Optional grounded shields
- Vacuum potting
- Very low partial discharge effects
- PCB through hole mounting or faston types
- Custom-specific versions on request

## Typical Applications

- Gate drive circuit
- Power supplies
- Power converters
- Frequency converters
- Switching applications
- DC/DC converters
- Line coupling transformers in high-speed data transmission

## Technical Specifications

<b>Nominal operating voltage</b>	Up to 3000 V
<b>Ignition currents</b>	0.1 to 3 A @ 40°C
<b>Operating frequency</b>	40 kHz max. DC to 40000 Hz 500 kHz max. for data transmission DC to 40000 Hz
<b>Rise time</b>	0.3 to 2.3 µs
<b>Test voltage</b>	Up/50 Hz/2 s max. according to VDE 110b
<b>Max. partial discharge voltage</b>	1.5 x Unom
<b>Temperature range (operation and storage)</b>	-25°C to +70°C (25/70/21)
<b>Flammability corresponding to</b>	UL 94 V-0 listed materials

## Pulse Transformer Selection Table

Pulse transformer	Turns ratio	Ignition current I <sub>ign</sub> [A]	Voltage		Voltage time area V0t [Vμs]	Rise time tr [μs]	Inductance*		Resistance		Coupling capacitance Ck [pF]	Input/ Output connections	Weight [g]
			Unom [V]	Up [kV]			Lp [mH]	Lstr [μH]	Rp [Ω]	Rs [Ω]			
IT 155	1:1	0.1	500	4	480	1	5	85	1.2	1.2	6	02	13
IT 245	1:1	0.1	750	4	500	1.2	8	100	1.48	1.48	10	02	6
IT 237	1:1	0.25	500	2.5	1100	1	25	35	1.9	2.2	50	02	14
IT 239	1:1	0.25	1000	6	300	2.3	3	80	0.9	0.9	5	02	13
IT 255	1:1	0.25	750	4	250	1.1	2.2	40	0.8	0.8	8	02	6
IT 258	1:1	1	750	3.2	250	0.25	2.5	3	0.62	0.75	80	02	6
IT 370	1:1	1	1000	5	4000	0.6	0.3	6	0.16	0.18	40	02	71
IT 364**	1:1	3	3000	8	5000	1.7	1.5	10	0.16	0.14	35	05	220
IT 246	2:1	0.1	750	4	200	0.4	7	35	2.1	1.1	7	02	6
IT 248	2:1	0.25	750	3.2	350	2.2	17	80	3.2	1.6	9	02	6
IT 260	3:1	0.1	500	3.2	200	0.3	12	30	2	0.8	8	02	6

\* Tolerance: +50%; -30%

\*\* Not suitable for PCB-mounting.

### Explanations:

– tr rise time at given load resistor R and 70% of the output pulse height.

– Lp primary inductance measured at 1 kHz (secondary coil open).

– Lstr stray inductance measured at the secondary side, short circuit at the primary side. If there are several secondary coils only one at the time is connected (measuring frequency 10 kHz).

– The ignition current is a set peak value where the voltage drop over the coil resistance is still insignificant (mostly below 1 V).

### Mechanical Data

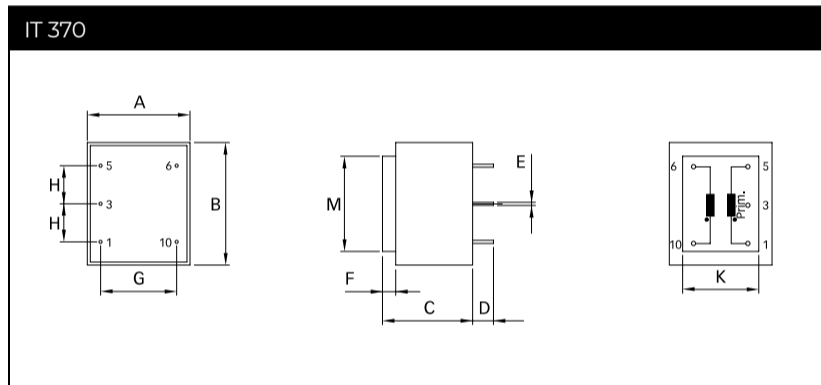
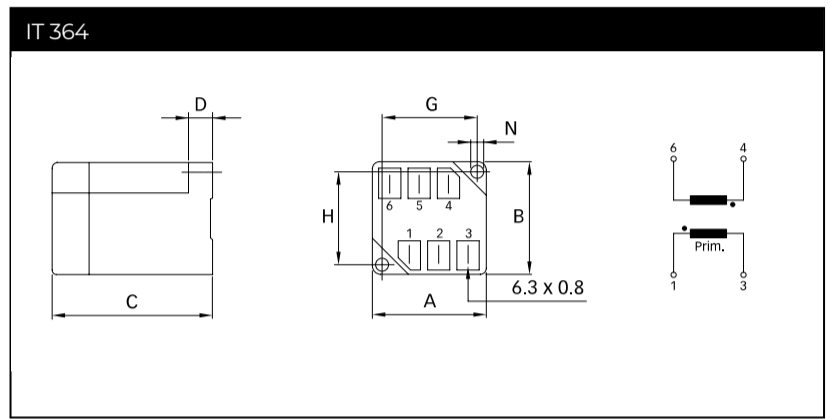
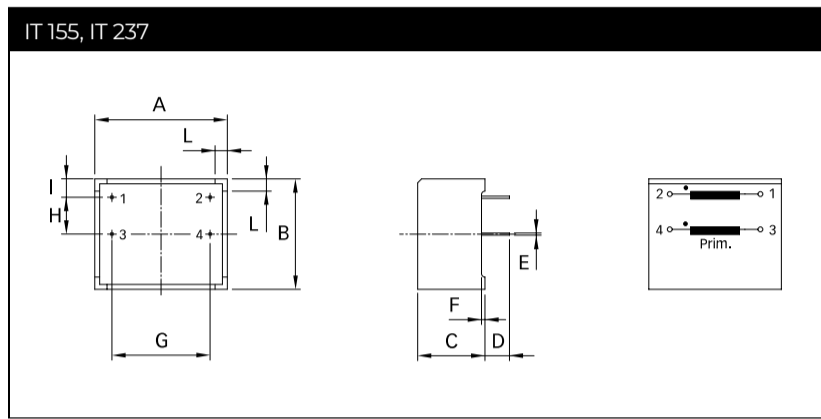
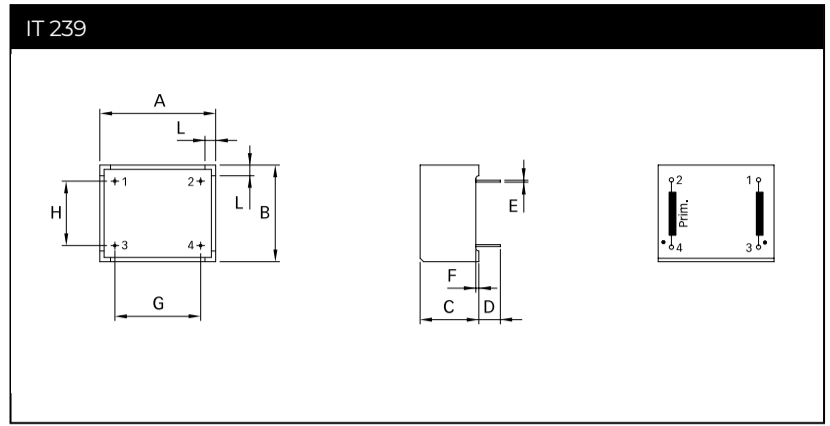
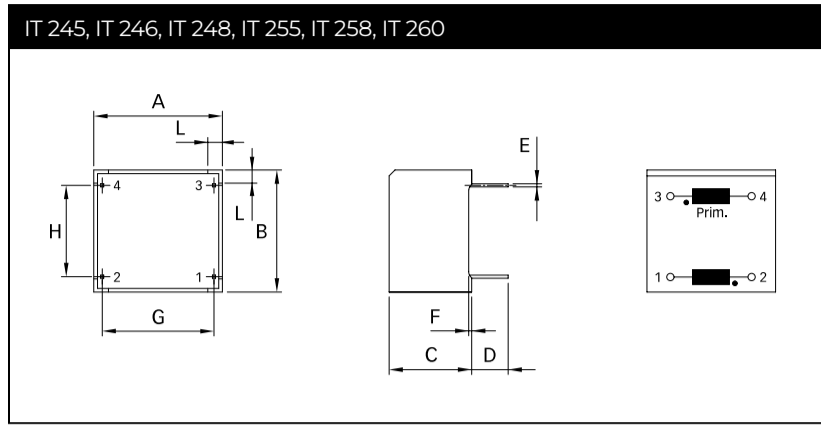

### Dimensions

	IT 245	IT 246	IT 248	IT 255	IT 258	IT 260	IT 239	IT 155	IT 237	IT 364	IT 370	Tol.
<b>A</b>	17.6*	17.6*	17.6*	17.6*	17.6*	17.6*	27	27	27	50	27	±0.2
<b>B</b>	16.7*	16.7*	16.7*	16.7*	16.7*	16.7*	22.5	22.5	22.5	50	32.2	±0.2
<b>C</b>	11.3*	11.3*	11.3*	11.3*	11.3*	11.3*	13.7	13.7	13.7	60	23.7	±0.2
<b>D</b>	5	5	5	5	5	5	5	5	5	10*	5.5	+1/-0
<b>E</b>	0.42	0.42	0.42	0.42	0.42	0.42	0.45	0.45	0.45		∅0.8	
<b>F</b>	0.4	0.4	0.4	0.4	0.4	0.4	0.7	0.7	0.7		3.5	
<b>G</b>	15.3	15.3	15.3	15.3	15.3	15.3	20	20	20	42	20	±0.2
<b>H</b>	12.5	12.5	12.5	12.5	12.5	12.5	15	7.5	7.5	42	10	±0.2
<b>I</b>								3.5	3.5			±0.2
<b>L</b>	2	2	2	2	2	2	2.5	2.5	2.5			
<b>M</b>											25	±0.2
<b>N</b>										∅4.2		

\* Tolerance is ±0.1

All dimensions in mm; 1 inch = 25.4 mm

Tolerances according: ISO 2768-m/EN 22768-m

Please visit [www.schaffner.com](http://www.schaffner.com) to find more details on connectors.

## Headquarters, Global Innovation and Development

### Switzerland

**Schaffner Group**  
Industrie Nord  
Nordstrasse 5  
4542  
Luterbach  
+41 32 681 66 26  
[info@schaffner.com](mailto:info@schaffner.com)

## Sales and Application Centers

### China

**Schaffner EMC Ltd. Shanghai**  
T20-3 C No 565 Chuangye Road Pudong district  
201201  
Shanghai  
+86 2138139500  
[cschina@schaffner.com](mailto:cschina@schaffner.com)

### Sweden

**Schaffner EMC AB**  
Östermalmstrorg 1  
114 42  
Stockholm  
+46 8 5050 2425  
[swedensales@schaffner.com](mailto:swedensales@schaffner.com)

### Switzerland

**Schaffner EMV AG**  
Industrie Nord  
Nordstrasse 5  
4542  
Luterbach  
+41 32 681 66 26  
[switzerlandsales@schaffner.com](mailto:switzerlandsales@schaffner.com)

### India

**Schaffner India Pvt. Ltd**  
Regus World Trade Centre  
WTC 22nd Floor Unit No 2238 Brigade Gateway Campus 26/1 Dr. Rajkumar Road Malleshwaram (W)  
560055  
Bangalore  
+91 8067935355  
[indiasales@schaffner.com](mailto:indiasales@schaffner.com)

### Italy

**Schaffner EMC S.r.l.**  
Via Ticino, 30  
20900  
Monza (MB)  
+39 335 120 44 32  
[italysales@schaffner.com](mailto:italysales@schaffner.com)

### Japan

**Schaffner EMC K.K.**  
ISM Sangenjaya 7F  
1-32-12 Kamiyama Setagaya-ku  
154-0011  
Tokyo  
+81 3 5712 3650  
[japansales@schaffner.com](mailto:japansales@schaffner.com)

### Singapore

**Schaffner EMC Pte Ltd.**  
Blk 3015A Ubi Road 1 #05-09 Kampong Ubi Industrial Estate  
408705  
Singapore  
+65 63773283  
[singaporesales@schaffner.com](mailto:singaporesales@schaffner.com)

### Finland

**Schaffner Oy**  
Lohjanharjuntie 1109  
08500  
Lohja  
+ 358 50 468 72 84  
[finlandsales@schaffner.com](mailto:finlandsales@schaffner.com)

### France

**Schaffner EMC S.A.S.**  
16-20 Rue Louis Rameau  
95875  
Bezons  
+33 1 34 34 30 60  
[francesales@schaffner.com](mailto:francesales@schaffner.com)

### Germany

**Schaffner Deutschland GmbH**  
Ohiostr. 8  
76149  
Karlsruhe  
+49 721 56910  
[germanysales@schaffner.com](mailto:germanysales@schaffner.com)

### Thailand

**Schaffner EMC Co. Ltd.**  
Sathorn Square Tower  
Room 3780 37FL 98 North-Sathorn Rd Silom Bangrak  
10500  
Bangkok  
+66 621056397  
[thailandsales@schaffner.com](mailto:thailandsales@schaffner.com)

### United Kingdom

**Schaffner Ltd.**  
Suite 1 Oakmede Place  
Terrace Road  
RG42 4JF  
Binfield  
+44 118 9770070  
[schaffner.uksales@te.com](mailto:schaffner.uksales@te.com)

### United States

**Schaffner EMC Inc.**  
52 Mayfield Avenue  
Edison, New Jersey  
+1 732 225 9533  
[usasales@schaffner.com](mailto:usasales@schaffner.com)

To find your local partner within Schaffner's global network [schaffner.com](http://schaffner.com)

© 2025 Schaffner Group

The content of this document has been carefully checked and understood. However, neither Schaffner nor its subsidiaries assume any liability whatsoever for any errors or inaccuracies of this document and the consequences thereof. Published specifications are subject to change without notice. Product suitability for any area of application must ultimately be determined by the customer. In all cases, products must never be operated outside their published specifications. Schaffner does not guarantee the availability of all published products. This disclaimer shall be governed by substantive Swiss law and resulting disputes shall be settled by the courts at the place of business of Schaffner Holding AG. Latest publications and a complete disclaimer can be downloaded from the Schaffner website. All trademarks recognized.